



Jim Hurst  
Chair

Doug Albin  
Vice Chair

Richard Shoemaker  
Commissioner

Dan Platt  
Commissioner

Grant Downie  
Commissioner

Anna Neumann  
Harbormaster

## **Noyo Harbor Commission Regular Meeting Agenda**

**Thursday May 9th, 2024**

**Fort Bragg Town Hall**

**363 N. Main Street, Fort Bragg, CA 95437**

### **Call to Order**

### **Roll Call**

### **Pledge of Allegiance**

### **Public Comment on Non-Agenda Items**

The Noyo Harbor Commission welcomes input from the public. Please limit your comments to five minutes so that everyone may be heard. The Brown Act does not allow action to be taken on non-agenda items.

### **Correspondence**

None

### **Consent Calendar**

1. Meeting Minutes – April 2024
2. Special Meeting Minutes- April 2024
3. Treasurer Report -April 2024

### **Conduct of Business**

1. Discussion and possible action Resolution 2024-2 Abandonment of Baby Sea Lion
2. Discussion and possible action on payment schedule for North Star Ice
3. Discussion and possible action on fish cleaning station contracts
4. Discussion and possible action on proposed budget 2024/2025

5. Discussion and possible action on meeting schedule for June through August.

**Staff Reports and Recommendations**

**District Office:**

Port Infrastructure Development Program

Harbormaster Maternity Leave

**Attorney Report:**

**Matters from the Commissioners:**

**Adjournment to the next regular meeting June 13<sup>th</sup> 2024 at 6pm**

NOYO HARBOR DISTRICT  
STATEMENT OF ACCOUNTS  
4/31/2024

Chase Checking	\$185,143.02
Chase Money Market	\$156,125.24
LAIF	\$1,553,442.17
Total of all accounts	\$1,894,710.43
Funds Reserved for State Lands Commission Grant	\$115,294.87
Funds Reserved for Economic Development Grant	\$53,786.32
<b>Unsecured funds</b>	<b>\$1,725,629.24</b>

# Noyo Harbor District Profit & Loss

April 2024  
Apr 24

Ordinary Income/Expense	
Income	
Electricity	796.44
Income / Mdco. County Taxes	48,907.75
Interest Income	16,769.07
Main Pier	295.69
Park & Launch	456.00
Slip Rental Contract	39,428.49
Slip Rental Transient	3,459.91
Total Income	<u>110,113.35</u>
Gross Profit	110,113.35
Expense	
Advertising Expense	16.72
Communications Expense	308.36
Deferred Maintenance	52.41
Dues and Subscriptions Exp	171.95
Emp. Health & Dental Insurance	2,201.84
Fuel Expense	209.16
Insurance Property & Liability	1,300.00
Legal and Professional Fees	1,760.29
Office Expense	1,466.70
Payroll Tax Expense	3,901.29
Power	3,927.70
Repairs & Maintenance	5,970.32
Salary Expense	2,354.31
Sep. Ira	683.93
Utilities Expense	5,151.51
Wages Expense (Hourly)	11,238.46
Total Expense	<u>40,714.95</u>
Net Ordinary Income	69,398.40
Other Income/Expense	
Other Expense	
2021-2022 SAVE Grant	-43,350.00
EDD Project	606,153.56
SLC Vessel Demo	0.00
Total Other Expense	<u>562,803.56</u>
Net Other Income	<u>-562,803.56</u>
Net Income	<u><u>-493,405.16</u></u>

	FY Year to Date	Budget	\$ Over Budget	% of Budget
<b>Income</b>				
Electricity	\$11,214.67	\$10,000.00	1,214.67	112.15
Encroachment Leases	\$24,759.36	\$20,000.00	4,759.36	123.80
Fish Markets	\$2,362.00	\$3,000.00	-638.00	78.73
Ground Rent	\$1,498.64	\$30,000.00	-28,501.36	5.00
Hoist Fees	\$0.00	\$1,000.00	-1,000.00	0.00
Income / Mdco. County				
Taxes	\$130,807.64	\$117,260.00	13,547.64	111.55
Interest Income	\$49,433.58	\$30,000.00	19,433.58	164.78
Late Fees	\$2,083.61	\$2,000.00	83.61	104.18
Main Pier	\$495.69	\$1,000.00	-504.31	49.57
Other Grant Proceeds	\$200.00	\$20,000.00	-19,800.00	1.00
Park & Launch	\$31,230.00	\$25,000.00	6,230.00	124.92
Slip Rental Contract	\$361,434.09	\$456,000.00	-94,565.91	79.26
Slip Rental Transient	\$39,652.73	\$43,000.00	-3,347.27	92.22
<b>Total Income</b>	<b>\$655,172.01</b>	<b>\$758,260.00</b>	<b>-\$103,087.99</b>	<b>86.40</b>
<b>Expense</b>				
Advertising Expense	\$266.46	\$8,000.00	-7,733.54	3.33
Communications Expense	\$3,704.53	\$4,500.00	-795.47	82.32
Deferred Maintenance	\$52.41	\$10,000.00	-9,947.59	0.52
Dues and Subscriptions Exp	\$9,798.01	\$10,000.00	-201.99	97.98
Emp. Health & Dental				
Insurance	\$23,743.84	\$24,000.00	-256.16	98.93
Fuel Expense	\$26,734.27	\$5,000.00	21,734.27	534.69
Insurance Property & Liability	\$219,952.56	\$210,000.00	9,952.56	104.74
Legal and Professional Fees	\$31,112.14	\$57,500.00	-26,387.86	54.11
Office Expense	\$7,807.81	\$11,800.00	-3,992.19	66.17
Operating Supplies	\$4,629.82	\$7,000.00	-2,370.18	66.14
Payroll Tax Expense	\$11,771.21	\$17,000.00	-5,228.79	69.24
Power	\$46,302.66	\$55,000.00	-8,697.34	84.19
Refund	\$707.10	\$1,000.00	-292.90	70.71
Repairs & Maintenance	\$27,946.40	\$28,000.00	-53.60	99.81
Salary Expense	\$53,827.12	\$70,000.00	-16,172.88	76.90
Sep. Ira	\$6,951.27	\$8,100.00	-1,148.73	85.82
Taxes & Assessments	\$1,472.99	\$3,000.00	-1,527.01	49.10
Travel and Conferences	\$1,750.49	\$5,000.00	-3,249.51	35.01
Utilities Expense	\$57,128.29	\$68,000.00	-10,871.71	84.01
Wages Expense (Hourly)	\$90,730.94	\$116,000.00	-25,269.06	78.22
<b>Total Expense</b>	<b>\$626,390.32</b>	<b>\$718,900.00</b>	<b>-92,509.68</b>	<b>87.13</b>
<b>Net Income</b>	<b>\$28,781.69</b>	<b>\$39,360.00</b>		<b>73.12</b>

# Noyo Harbor District

## Payroll summary by employee report

From Apr 01, 2024 to Apr 30, 2024 for all employees from all locations

Item	Total
<b>Hours - total</b>	<b>622.34</b>
Hours - Regular Pay	441
Hours - Vacation Pay	0
Hours - Sick Pay	8
Hours - Holiday Pay	0
Hours - Salary	173.34
<b>Gross pay - total</b>	<b>\$ 16,676.88</b>
Gross pay - Regular Pay	\$ 10,796.80
Gross pay - Vacation Pay	\$ 0.00
Gross pay - Sick Pay	\$ 230.08
Gross pay - Holiday Pay	\$ 0.00
Gross pay - Salary	\$ 5,650.00
<b>Pretax deductions - total</b>	
<b>Adjusted gross</b>	<b>\$ 16,676.88</b>
<b>Other pay - total</b>	<b>\$ 0.00</b>
<b>Employee taxes &amp; deductions - total</b>	<b>-\$ 3,084.11</b>
<b>Employee taxes - total</b>	<b>-\$ 3,084.11</b>
Employee taxes - Federal Income Tax	-\$ 1,243.60
Employee taxes - Social Security	-\$ 1,033.97
Employee taxes - Medicare	-\$ 241.81
Employee taxes - CA Income Tax	-\$ 381.27
Employee taxes - CA State Disability Ins	-\$ 183.46
<b>Employee Aftertax deductions - total</b>	
<b>Net pay</b>	<b>\$ 13,592.77</b>
<b>Employer taxes &amp; contributions - total</b>	<b>\$ 1,391.88</b>
<b>Employer taxes - total</b>	<b>\$ 1,391.88</b>
Employer taxes - FUTA Employer	\$ 29.02
Employer taxes - Social Security Employer	\$ 1,033.97
Employer taxes - Medicare Employer	\$ 241.81
Employer taxes - CA ETT	\$ 4.84
Employer taxes - CA SUI Employer	\$ 82.24
<b>Company contributions - total</b>	
<b>Total payroll cost</b>	<b>\$ 18,068.76</b>



Jim Hurst  
Chair

Doug Albin  
Vice Chair

Richard Shoemaker  
Commissioner

Dan Platt  
Commissioner

Grant Downie  
Commissioner

Anna Neumann  
Harbormaster

## **Noyo Harbor Commission Special Meeting Minutes**

**Thursday April 23rd, 2024**

**2-4pm**

**Noyo Marine Science Center Field Station**

**32430 N. Harbor Drive, Fort Bragg, CA, 95437**

**Call to Order at 2:10pm**

**Roll Call**

**Present:** Commissioner Shoemaker, Commissioner Downie, Chair Hurst

**Staff Present:** Harbormaster Anna Neumann, Legal Council James Jackson, Nick Savedra

**Public Comment on Non-Agenda Items**

None

**Correspondence**

None

**Consent Calendar**

None

**Vice Chair Albin arrived at 2:23pm**

**Conduct of Business**

1. Presentation from Shelia Semans and Don Perkins – Noyo Center for Marine Science Blue Economy Feasibility Study

Sheila Semans and Don Perkins gave a presentation on their Blue Economy Feasibility Study and asked the commissioners questions on where they thought the Harbor District and the Noyo Center for Marine Science could collaborate.

A conversation on the Noyo Centers need for sea water was had and what it would like life if the District provided sea water as a utility.

A conversation on the needs of the commercial fishing fleet was had and how the Noyo Center could potentially help fill those needs.

**Commissioners Downie left at 3:03pm**

A conversation on different grant programs was held and how the District and the Noyo Center could collaborate.

**No motion was made.**

**Staff Reports and Recommendations**

**District Office:**

None

**Attorney Report:**

None

**Matters from the Commissioners:**

None

**Motion for Adjournment to the next regular meeting of May 9th 2024 at 6pm. 1<sup>st</sup>  
Commissioner Albin, 2<sup>nd</sup> Commissioner Shoemaker**





Jim Hurst  
Chair

Doug Albin  
Vice Chair

Richard Shoemaker  
Commissioner

Dan Platt  
Commissioner

Grant Downie  
Commissioner

Anna Neumann  
Harbormaster

## **Noyo Harbor Commission Regular Meeting Minutes**

**Thursday April 11th, 2024**

**Fort Bragg Town Hall**

**363 N. Main Street, Fort Bragg, CA 95437**

**Call to Order at 6:00pm**

**Roll Call**

**Present:** Commissioner Shoemaker, Commissioner Platt, Commissioner Downie, Vice Chair Albin, Chair Hurst

Staff Present: Anna Neumann, Jim Jackson, Nick Savedera

**Pledge of Allegiance**

**Public Comment on Non-Agenda Items**

The Noyo Harbor Commission welcomes input from the public. Please limit your comments to five minutes so that everyone may be heard. The Brown Act does not allow action to be taken on non-agenda items.

**None**

**Correspondence**

Jade Tippett – Mendocino Railway

A brief discussion was held on the Mendocino Railway and their plans to develop rail lines that would follow the Noyo River. Commissioner Downie asked the Harbormaster what the greatest concerns would be and she noted that increased sediment into the Noyo might affect the dredging cycles for the marina and the aquatic life in the river. The commissioners requested the Harbormaster keep them informed of any activity on the project.

**Consent Calendar**

1. Meeting Minutes – March 2024
2. Treasurer Report -March 2024

**Motion to approve the consent calendar with edits to the minutes. 1<sup>st</sup>. Commissioner Albin, 2<sup>nd</sup> Commissioner Platt. Approved 5-0-0**

### **Conduct of Business**

1. Discussion and possible action on Blacktail Insurance

Chair Hurst spoke in favor of moving forward with Blacktail Insurance. He has used Mr. Hall in the past and felt his local presence was strong and he would be successful in his new company.

**Motion to authorize the Harbormaster to sign paperwork to change the Agent of Record on for the Harbor District's insurance. Approved 5-0-0**

2. Discussion on Fleet Meeting

The Harbormaster reviewed the plan for the upcoming fleet meeting and the participants that she hoped would participate. Chair Hurst asked if the Commissioners should join and the Harbormaster encouraged commissioner participation so they too, can better understand the needs of the fleet. No motion was made.

3. Discussion and possible action EDD Grant Update

The Harbormaster gave an update on the progress West Center has made on the community market places and marine based trainings, including how their work would develop a new website for the Harbor District. The Harbormaster also present the plans SHN developed for the installation of the icehouse behind the Harbor Office. Commissioners asked general questions.

**Motion to authorize the Harbormaster to complete the deposit to North Star Ice. 1<sup>st</sup> Platt, 2<sup>nd</sup> Downie. Approved 5-0-0**

4. Discussion on MCOG Noyo Harbor Multimodal Circulation Plan

Harbormaster informed the commissioners of the Mendocino Council of Governments plans to complete the Multimodal Circulation Plan. The Harbormaster requested to be on the Technical Advisory Group for the project to ensure that the project understands the needs of the fleet. No motion was made.

5. Discussion and possible action on making the Marina Manager position a full-time position.

A discussion was held on the need to move the marina manager position to full time. Chair Hurst gave a background on how many employees the Harbor District traditionally supported and why they down graded to just one employee in the office when the current Harbormaster was hired. Commissioner Shoemaker agreed there should be two people in the office and suggested that the office be open 7 days a week. The Harbormaster said it would be best to wait until after her maternity leave to transition someone to working the weekends.

**Motion to authorize the Harbormaster to hire the Marina Manager full time. 1<sup>st</sup>  
Commissioner Shoemaker, 2<sup>nd</sup> Commissioner Platt. 5-0-0**

6. Discussion and possible action on Financial Services RFQ

The Harbormaster detailed the lack of interest in the Financial Services RFQ and hoped that they could re-post the request after tax season when bookkeepers and those in the financial industry would not be as heavily burdened with work. The Harbormaster does have one meeting with the only respondent, however the respondent was unable to commit to the District long term as they had taken up other work since responding to the RFQ.

**Commissioners directed the Harbormaster to meet with the respondent and continue to seek help for the financial department.**

**Staff Reports and Recommendations**

**District Office:**

The Harbormaster presented information to the Commissioners about the upcoming special meeting with the Noyo Center for Marine Science and on the State Conservancy pre-application. The Harbormaster also gave an update on the Federal Resource meeting she attended for the last two days and the hopeful connections made at those meetings.

**Attorney Report:**

None

**Matters from the Commissioners:**

**Commissioner Downie-** Commissioner Downie reported that he has been working with Oneka on the desalination buoy. He is also participating in Kelp Fest from May to June. Commissioner Downie also spoke on the new mandatory descending device that recreational fishermen need to carry as they are fishing deeper and deeper waters due to regulations.

**Commissioner Platt-** Commissioner Platt reported that he read the Noyo Harbor District's letter to the Pacific Marine Fisheries Council into the public minutes. He also read another letter from a local young fishermen regarding rockfish regulations into the public minutes and stated both letters seemed to be well received.

**Motion for adjournment to the next regular meeting May 9th 2024 at 6pm at 7:35pm. 1<sup>st</sup>  
Commissioner Albin, 2<sup>nd</sup> Commissioner Downie. 5-0-0**



**Page Left Blank**

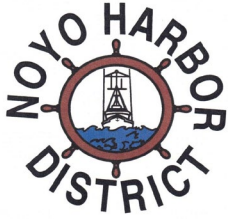

# NOYO HARBOR DISTRICT AGENDA ITEM SUMMARY

**AGENDA ITEM #: 1**  
**MEETING DATE: 5/9/2024**

## TITLE

Resolution for abandonment Baby Sea Lion

## RECOMMENDED ACTION

## ANALYSIS

The owner of the Baby Sea Lion has passed and the family has no interest or intention of continuing to pay the Harbor District for the slip rent on the Baby Sea Lion. There are also no registration numbers on this vessel so the Harbormaster has very little means in which to lien and sell the vessel. Overall the vessel is not in the best shape and would likely not sell in the current market. The commissioners should consider declaring this an abandon vessel under HNC 525 and using SAVE grant funding to remove and dispose of this vessel.

Gary Swanson has provided the following quote to dismantle the vessel.

## FISCAL IMPACT

SAVE grants require a 10% match but staff time can be used as an in-kind match. The District has \$40,360 left in their 2022/2023 SAVE grant which must be expended by 9/30/2024.

## ATTACHMENTS

Resolution of Abandonment 2024-2

Quote from Gary Swanson to dismantle the vessel



**Page Left Blank**

NOYO HARBOR DISTRICT  
RESOLUTION NO. 2024-2

WHEREAS, on May 1, 2024 the vessel Baby Sea Lion owned by Kenneth Moore was abandoned by its owner, and

WHEREAS, more than Thirty (30) days have passed without a watchman or other person being maintained on or near the vessel, and

WHEREAS, the vessel is in an unseaworthy dilapidated condition and is located upon publicly owned submerged lands or tidelands within the jurisdiction of the Noyo Harbor District, and

WHEREAS, the Noyo Harbor District has control over the submerged lands and tidelands within the Noyo River, and the vessel Baby Sea Lion remains in the Noyo Harbor without the District's consent;

IT IS HEREBY RESOLVED THAT:

1. The District hereby declares the vessel Kenneth Moore to be abandoned by its owner Kenneth Moore.

2. The District hereby takes title to the abandoned property in accordance with California Harbors and Navigation Code § 522.

3. The District may hereafter cause the vessel Baby Sea Lion to be sold, destroyed, or otherwise disposed of in any manner as it may determine is expedient or convenient. In the event the vessel Baby Sea Lion is sold by the District, the District may retain any proceeds derived from such sale.

4. In accordance with California Harbors and Navigation Code § 525 the abandonment of the vessel Samurai constitutes prima facie evidence that the last registered owner of record (Kenneth Moore) is responsible for the abandonment and is thereby liable for the cost of removal and disposition of the vessel.

PASSED AND ADOPTED, by the Noyo Harbor Commissioners of the Noyo Harbor District on February 9, 2023 by the following vote:

AYES:	Commissioners	_____
NOES:	Commissioners	_____
ABSENT:	Commissioners	_____

ATTEST: \_\_\_\_\_  
Anna Neumann, Harbormaster  
Noyo Harbor District

\_\_\_\_\_  
Jim Hurst, Chairman  
Noyo Harbor District



**Page Left Blank**







**Page Left Blank**

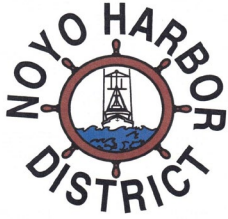

## NOYO HARBOR DISTRICT AGENDA ITEM SUMMARY

**AGENDA ITEM #: 2**  
**MEETING DATE: 5/9/2024**

### TITLE

Payment Schedule for North Star Ice

### RECOMMENDED ACTION

Approval or recommendations to proceed

### ANALYSIS

The District was able to successfully transfer the deposit for the icehouse to North Star Ice in March but still has an outstanding bill of \$765,498. Establishing a monthly payment schedule would allow us to slowly pay off the remainder without overly taxing the District's reserves. North Star would like to be paid in full by December 2024.

The following payment schedule would the District to be paid in full by December 2024.

Payment Date	Amount	Remaining Balance
4/15/2024	\$600,00	\$765,798
6/1/2024	\$109,357	\$656,141
7/1/2024	\$109,357	\$546,784
8/1/2024	\$109,357	\$437,427
9/1/2024	\$109,357	\$328,070
10/1/2024	\$109,357	\$218,713
11/1/2024	\$109,357	\$109,357
12/1/2024	\$109,357	0

### FISCAL IMPACT

Program is 100% grant funded but will affect cash flows as reimbursements are also submitted monthly to EDD

### ATTACHMENTS



**Page Left Blank**

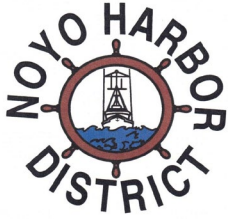

# NOYO HARBOR DISTRICT AGENDA ITEM SUMMARY

**AGENDA ITEM #: 3**  
**MEETING DATE: 5/9/2024**

## TITLE

Contract for Fish Cleaning Station Construction Project

## RECOMMENDED ACTION

## ANALYSIS

The following contract would go out to bid for potential contractors to bid on the construction of the fish cleaning station.

Ideally, this contract would be approved and an award will be made in July.

## FISCAL IMPACT

## ATTACHMENTS

Contract



**Page Left Blank**

# **Contract Documents**

**For**

## **Noyo Harbor District Fish Cleaning Station**

**Noyo Harbor District  
Fort Bragg, Mendocino County, California**

(Bidding Requirements, General Conditions, Special  
Provisions and Construction Agreement)

**Bid Opening Date: June 4, 2024, at 2:00 p.m.**

**This Page Left Intentionally Blank.**



# Introductory Notice to Bidders:

## 1. Questions Concerning Bid Items:

Questions concerning interpretation of the General Conditions and Contract Documents, and bid items shall be directed to:

Noyo Harbor District  
Anna Neumann, Harbormaster  
19101 S. Harbor Drive  
Fort Bragg, CA 95437  
(707) 964-4719  
[noyohd@yahoo.com](mailto:noyohd@yahoo.com)

Office hours: Monday through Friday, 8:00 a.m. to 5:00 p.m.

## 2. Project Contacts

Owner:

Noyo Harbor District  
Anna Neumann, Harbormaster  
19101 S. Harbor Drive  
Fort Bragg, CA 95437  
(707) 964-4719  
[noyohd@yahoo.com](mailto:noyohd@yahoo.com)  
Noyo Harbor District

Construction Manager:

SHN Engineers & Geologists  
Jason Island, Construction Manager  
335 S. Main Street  
Willits, CA 95490  
(707) 459-4518

**This Page Left Intentionally Blank.**

# Table of Contents

	Page
<b>Section I: Bidding Requirements</b>	
Introductory Notice to Bidders: .....	i
Notice Inviting Bids .....	1
Instructions to Bidders.....	3
Proposal .....	11
Bid Schedule.....	13
Non-Collusion Affidavit .....	17
Questionnaire and Financial Assurance Statement Form .....	19
Bid Bond.....	21
Performance Bond .....	23
List of Subcontractors .....	27
Bid Proposal Certificate.....	1
Attachments.....	Follow Page 32
1. Assurances for Compliance with Federal Laws and Regulations .....	2
2. Equal Employment Opportunity Certification .....	4
3. Debarment and Suspension Certification .....	6
4. Nonlobbying Certification For Federal-Aid Contracts.....	8
5. Disclosure of Lobbying Activities .....	10



## Notice Inviting Bids

Noyo Harbor District  
Fish Cleaning Station

1. Notice is hereby given that sealed Bids will be received by the Noyo Harbor District (District) located at 19101 S. Harbor Drive, Fort Bragg, California 95437, until 2:00 p.m., on Tuesday, June 4, 2024, for the Fish Cleaning Station project. Any Bids received after the specified time and date will not be considered. Fax and other electronically transmitted Bids will not be accepted.
2. Opening of Bids: The Bids will be publicly opened and read at 2:00 p.m., on June 4, 2024, at the above-mentioned office of the District. The District reserves the right to postpone the date and time for opening of Bids at any time prior to the aforesaid date and time.
3. Description of Work: The performance of all the work and the furnishing of all the labor, supplies, tools, and equipment to construct a new covered fish cleaning station, extension of concrete sidewalk, new post and rope fencing adjacent to proposed sidewalks along the riverbank, new "Caught from Noyo Harbor" bulletin board sign, new cold-water shower, connections to utilities including water, sewer, and stormwater.
4. Project Costs: Engineer's opinion of probable cost to perform this work is \$109,150.
5. Site of Work: The work site covered under this contract is within the Noyo Harbor District. The Fish Cleaning Station Project is located at Grader Park, 19101 S. Harbor Drive, Fort Bragg, California 95437.
6. Permits: The District will obtain all required permits for the Work.
7. Obtaining Contract Documents: The Contract Documents are entitled Noyo Harbor Fish Cleaning Station Project. An electronic copy of the Contract Documents may be obtained by contacting the Noyo Harbor District by contacting Anna Neumann, Harbormaster, by email at [noyohd@yahoo.com](mailto:noyohd@yahoo.com) or by calling (707) 964-4791.
8. Bid Security: Each Bid shall be accompanied by a certified or cashier's check or Bid Bond executed by an admitted surety in the amount of 10 percent of the Total Bid Price payable to the Noyo Harbor District as a guarantee that the Bidder, if its Bid is accepted, will promptly execute the Agreement. A Bid shall not be considered unless one of the forms of Bidders security is enclosed with it. Upon acceptance of the Bid, if the Bidder refuses to or fails to promptly execute the Agreement, the Bidders security shall be forfeited to the District.
9. Contractor's License Classification: In accordance with the provisions of California Public Contract Code Section 3300, the District has determined that the Contractor shall possess a valid Class A license at the time that the Contract is awarded. Failure to possess the specified license shall render the Bid as non-responsive and shall act as a bar to award of the Contract to any bidder not possessing said license at the time of award.
10. Rejection of Proposals: The District reserves the right to reject all or any part of all bids submitted, waive informalities and irregularities, and will not, to the extent allowed by law, be bound to accept the lowest, responsive, responsible bid.

11. Bids To Remain Open: The Bidder shall guarantee the total bid price for a period of 90 calendar days from the date of bid opening.
12. Pursuant to California Labor Code Section 1771.1, this Project is subject to compliance monitoring and enforcement by the Department of Industrial Relations (DIR). A Contractor may not bid, nor be listed as a subcontractor for any bid proposal submitted for public work without first registering with the DIR and paying the annual fee. Application and renewal are completed online at <http://www.dir.ca.gov/Public-Works/PublicWorks.html>. No contractor or subcontractor may be awarded a contract for public work on a public works project unless registered with the Department of Industrial Relations pursuant to Labor Code section 1725.5. If you are not registered and are offered the contract for construction will need to register with DIR prior to the District executing the construction contract.
13. California Wage Rate Requirements: In accordance with the provisions of California Labor Code Sections 1771 and 1773 as amended, the Director of the Department of Industrial Relations has determined the general prevailing rate of per diem wages in accordance with the standards set forth in Section 1773 for the locality in which the Work is to be performed. It shall be mandatory upon the Contractor to whom the Work is awarded and upon any subcontractor under the Contractor to pay not less than said specified rates to all workers employed by them in the execution of the Work.
14. Project Administration: All communications, including project and bid related questions, relative to this Work shall be directed to the Harbor Master prior to close of business, Tuesday, May 21, 2024.

Name: Harbor Master, Project Manager  
Address: 19101 S. Harbor Drive  
Fort Bragg, CA 95437  
Telephone: (707) 964-4719 Fax: (707) 964-4710  
Email: [noyohd@yahoo.com](mailto:noyohd@yahoo.com)

District: Noyo Harbor District

By: Anna Neumann, Harbor Master

Date: May 10, 2024

End of Notice Inviting Bids

# Instructions to Bidders

## 1. Defined Terms

Terms used in these Instructions to Bidders and the Notice Inviting Bids which are defined in the General Conditions have the meanings assigned to them in the General Conditions. The term "Bidder" means one who submits a Bid directly to District, as distinct from a sub-bidder, who submits a price or quote to a Bidder.

## 2. Local Business License

All Contractors, including subcontractors, not already having a local business license for the work contemplated, will be required to secure the appropriate license before a Contract can be executed.

## 3. Interpretations and Addenda

3.1. All questions about the meaning or intent of the Contract Documents are to be directed to the Engineer. Additions, deletions, or revisions to the Contract Documents considered necessary by the Engineer in response to such questions will be issued by Addenda mailed or delivered to all parties recorded by the Engineer as having received the Contract Documents. Questions received less than 10 days prior to the date of Bid opening may not be answered. Only answers to such questions issued by formal written Addenda will be binding. Oral and other interpretations or clarifications will be without legal effect.

3.2. Addenda may also be issued to make other additions, deletions, or revisions to the Contract Documents.

3.3. Bidders shall make no special interpretation or inference of intent from differing formats in the Contract Documents.

## 4. Bidder's Examination of Contract Documents and Site

4.1. It is the responsibility of each Bidder before submitting a Bid:

- a. To examine thoroughly the Contract Documents and other related data identified in the Bidding Documents (including "technical" data referred to below);
- b. To visit the site to become familiar with local conditions that may affect cost, progress, or performance of the Work;
- c. To consider federal, state, and local Laws and Regulations that may affect cost, progress, or performance of the Work;
- d. To study and carefully correlate the Bidder's observations with the Contract Documents; and
- e. To notify the Engineer of all conflicts, errors, ambiguities, or discrepancies in or between the Contract Documents and such other related data.

4.2. The Contractor is required to have all local, state, and federal licenses, certifications, and permits required to fulfill each aspect of work under this agreement. NHD will not provide any licenses, permits, or certifications. All required licenses, permits, and certifications must be valid and active for the duration of the work required under this Work.

- 4.3. Information and data reflected in the Contract Documents with respect to Underground Utilities at or contiguous to the site are based upon information and data furnished to the Engineer by the owners of such Underground Utilities or others, and the District does not assume responsibility for the accuracy or completeness.
- 4.4. Provisions concerning responsibilities for the adequacy of data furnished to prospective Bidders on subsurface conditions, Underground Utilities, and other physical conditions, and possible changes in the Contract Documents due to differing conditions appear in Paragraphs 4.2, 4.3, and 4.4 of the General Conditions.
- 4.5. Before submitting a Bid, each Bidder will, at Bidder's own expense, make or obtain any additional examinations, investigations, explorations, tests, and studies and obtain any additional information and data which pertain to the physical conditions (surface, subsurface, and underground utilities) at or contiguous to the site or otherwise that may affect cost, progress, or performance of the Work and that the Bidder deems necessary to determine its Bid for performing the Work in accordance with the time, price, and other terms and conditions of the Contract Documents.
- 4.6. On request a minimum of 2 working days in advance, the Engineer will provide each Bidder access to the site to conduct such examinations, investigations, explorations, tests, and studies as each Bidder deems necessary for submission of a Bid. Location of any excavation or boring shall be subject to prior approval of Engineer and applicable agencies. Bidder shall fill all holes, restore all pavement to match existing structural section, and shall clean up and restore the site to its former condition upon completion of such explorations. Engineer reserves the right to require Bidder to execute an Access Agreement with the District prior to accessing the site.
- 4.7. The lands upon which the Work is to be performed, rights-of-way, and easements for access thereto and other lands designated for use by the Contractor in performing the Work are identified in the Contract Documents. All additional lands and access thereto required for temporary construction facilities or storage of materials and equipment are to be provided by the Contractor. Easements for permanent structures or permanent changes in existing structures are to be obtained and paid for by the District unless otherwise provided in the Contract Documents.
- 4.8. The submission of a Bid will constitute an incontrovertible representation by the Bidder that the Bidder has complied with every requirement of this Paragraph 4 and the following:
  - a. That the Bid is premised upon performing the Work required by the Contract Documents without exception and such means, methods, techniques, sequences, or procedures of construction (if any) as may be required by the Contract Documents;
  - b. That Bidder has given the Engineer written notice of all conflicts, errors, ambiguities, and discrepancies in the Contract Documents and the written resolution thereof by the Engineer is acceptable to the Bidder; and
  - c. That the Contract Documents are sufficient in scope and detail to indicate and convey understanding of all terms and conditions for performance of the Work.



## 5. Bid Forms

The Bid shall be submitted on the Bid Forms provided by the District. All blanks on the Bid Forms shall be completed in ink. All names must be printed below the signatures. The Bid shall be submitted in a sealed envelope which shall be plainly marked in the upper left hand corner with the name and address of the Bidder and shall bear the words "BID FORM" followed by the title of the Contract Documents for the Work, the name of the District, the address where Bids are to be delivered or mailed to, and the date and hour of opening of Bids.

- 5.1. Bid Supporting Documentation. Bidders shall provide in a separate, sealed envelope at the time of submittal of the Bid, all bid supporting documentation setting forth the underlying assumptions made by the Bidder in submitting its Bid.
- 5.2. The Bid must set forth the name and location of the place of business of each subcontractor who will perform work or labor or render service to the prime contractor in or about the construction of the Work, or a subcontractor licensed by the State of California who, under subcontract to the prime contractor, specially fabricates and installs a portion of the Work. According to detailed description of work, in an amount in excess of one-half of one percent (0.5%) of the prime Contractor's total bid or, in the case of bids or offers for the construction of streets and highways, including bridges, in excess of one-half of one percent (0.5%) of the prime contractor's total bid or Ten Thousand dollars (\$10,000), whichever is greater.

## 6. Certificates

- 6.1 Bids by corporations must be executed in the corporate name by the president, a vice president, or other corporate officer. Such Bid shall be accompanied by the enclosed Certificate of Authority to sign, attested by the secretary or assistant secretary, and with the corporate seal affixed. The corporate address and state of incorporation must appear below the signature.
- 6.2 Bids by partnerships must be executed in the partnership name and be signed by a managing partner, accompanied by the enclosed Certificate of Authority to sign, and his/her title must appear under the signature and the official address of the partnership must appear below the signature.
- 6.3 Bids by joint venture must be executed in the joint venture name and be signed by a joint venture managing partner, accompanied by the enclosed Certificate of Authority to sign, and his/her title must appear under the signature and the official address of the joint venture must appear below the signature.

## 7. Disqualification of Bidders

More than one Bid from an individual, firm, partnership, corporation, or association under the same or different names will not be considered. If the District believes that any Bidder is interested in more than one Bid for the Work contemplated, all Bids in which such Bidder is interested will be rejected. If the District believes that collusion exists among the Bidders, all Bids will be rejected. A party who has quoted prices to a bidder is not hereby disqualified from quoting prices to other Bidders, or from submitting a Bid directly for the Work.

8. Quantities of Work

The quantities of work or material stated in unit price items of the Bid are supplied only to give an indication of the general scope of the Work. The Owner does not expressly or by implication agree that the actual amount of work or material will correspond therewith, and reserves the right after award to increase or decrease the quantity of any unit price item of the Work by an amount up to and including 25 percent of any Bid item in its entirety, or to add additional Bid items up to and including an aggregate total amount not to exceed 25 percent of the Bid price.

9. Substitute Or "Or Equal" Items

Whenever materials or equipment are specified or described in the Contract Documents by using the name of a particular manufacturer and the name is followed by the words "or equal", the Bidder may write the name of a substitute manufacturer (which the Bidder considers as an "or equal") in the List of Proposed Substitutions in the Bid Forms. The Engineer will make a determination of approval or rejection of the proposed substitution prior to award of the Contract. No request for substitution of an "or equal" item will be considered by the Engineer after award of the Contract. The procedure for the submittal of substitute or "or equal" products is contained in the Bid Forms. The Bidder shall not be relieved of any obligations of the Contract Documents or be entitled to an adjustment in the Contract Price in the event any proposed substitution is not approved.

10. Competency of Bidders

In selecting the lowest responsive, responsible Bidder, consideration will be given not only to the financial standing but also to the general competency of the Bidder for the performance of the Work covered by the Bid. To this end, each Bid shall be supported by a statement of the Bidder's experience as of recent date including: (a) all projects worked on by the Bidder over the past three (3) years including the contract amount for each project; (b) all complaints made against the Contractor's license in the past ten (10) years; and (c) all claims and lawsuits presented or filed in the last five (5) years, regardless of the form, regarding any public works project.

11. Submission of Bids

The Bid shall be delivered by the time and to the place stipulated in the Notice Inviting Bids. It is the Bidder's sole responsibility to see that its Bid is received in proper time and at the proper place.

12. Bid Security, Bonds, and Insurance

Each Bid shall be accompanied by a certified or cashier's check or approved Bid Bond in the amount stated in the "Invitation to Bid." Said check or bond shall be made payable to the District and shall be given as a guarantee that the Bidder, if awarded the Work, will enter into an Agreement with the District and will furnish the necessary insurance certificates, Payment Bond, and Performance Bond. In case of refusal or failure to enter into said Agreement, the check or Bid Bond, as the case may be, shall be forfeited to the District. If the Bidder elects to furnish a Bid Bond as its Bid security, the Bidder shall use the Bid Bond form bound herein. Bid Bonds shall comply with the requirements applicable to payment and performance bonds in the General Conditions.

12.1 Bidding Capacity. Each Bid shall be accompanied by a list of the projects currently being worked on by Bidder, their size, contract price, scheduled completion date, location, and owner.

13. Discrepancies In Bids

In the event there is more than one Bid item in a Bid Schedule, the Bidder shall furnish a price for all Bid Items in the Schedule, and failure to do so will render the Bid non-responsive and shall cause its rejection. In the event there are unit price Bid items in a Bidding schedule and the amount indicated for a unit price Bid item does not equal the product of the unit price and quantity, the unit price shall govern and the amount will be corrected accordingly, and the Bidder shall be bound by said correction. In the event there is more than one Bid item in a Bid Schedule and the total indicated for the Schedule does not agree with the sum of the prices Bid on the individual items, the prices Bid on the individual items shall govern and the total for the Schedule will be corrected accordingly, and the Bidder shall be bound by said correction.

14. Modifications and Unauthorized Alternative Bids

Unauthorized conditions, limitations, or provisions attached to the Bid shall render it informal and may cause its rejection as being non-responsive. The Bid forms shall be completed without interlineations, alterations, or erasures in the printed text. Alternative Bids will not be considered unless called for. Oral, electronic, or telephonic Bids or modifications will not be considered.

15. Withdrawal of Bid

The Bid may be withdrawn by the Bidder by means of a written request, signed by the Bidder or its properly authorized representative. Such written request must be delivered to the place stipulated in the Notice Inviting Bids for receipt of Bids prior to the scheduled closing time for receipt of Bids.

16. Bid Protest

Any Bid protest must be submitted in writing to the Harbormaster before 5:00 p.m. on the fifth (5<sup>th</sup>) working day following Bid opening.

- a. The initial protest document must contain a complete statement of the basis for the protest, and all supporting documentation.
- b. The party filing the protest must have actually submitted a Bid for the Work. A subcontractor of a party submitting a Bid for the Work may not submit a Bid protest. A party may not rely on the Bid protest submitted by another Bidder, but must timely pursue its own protest.
- c. The protest must refer to the specific portion of the bid document which forms the basis for the protest.
- d. The protest must include the name, address and telephone number of the person representing the protesting party.
- e. The party filing the protest must concurrently transmit a copy of the initial protest document and any attached documentation to all other parties with a direct financial interest which may be adversely affected by the outcome of the protest. Such parties shall include all other Bidders who appear to have a reasonable prospect of receiving an award depending upon the outcome of the protest.

- f. The District will give the protested Bidder five (5) working days after the receipt of the protest to submit a written response. The responding Bidder shall transmit the response to the protesting Bidder concurrent with delivery to the District.
- g. The procedure and time limits set forth in this paragraph are mandatory and are the Bidder's sole and exclusive remedy in the event of Bid protest. The Bidder's failure to comply with these procedures shall constitute a waiver of any right to pursue the Bid protest further, including filing a Government Code Claim or legal proceedings.
- h. If the District determines that a protest is frivolous, the protesting bidder may be determined to be non-responsible and that bidder may be determined to be ineligible for future contract awards.

17. Award of Contract

Award of the contract, if awarded, will be made to the lowest responsive, responsible Bidder -whose Bid complies with the requirements of the Contract Documents. Unless otherwise specified, any such award will be made within the period stated in the Notice Inviting Bids that the bids are to remain open. Unless otherwise indicated, a single award will be made for all the Bid items in an individual Bid Schedule. In the event the Work is contained in more than one Bid Schedule, the District may award Schedules individually or in combination. In the case of two Bid Schedules that are alternative to each other, only one of such alternative schedules will be awarded. The District may condition the award upon the Bidder's timely submission of all items required by the Contract Documents, including, but not limited to the executed Agreement, performance, labor and materials, and maintenance bonds, and required certificates of insurance and endorsements.

18. Return of Bid Security

Within 14 days after award of the contract, the District will, if requested, return the Bid securities accompanying such Bids that are not being considered in making the award. All other Bid securities will be held until the Agreement has been finally executed. They will then be returned, if requested, to the respective Bidders whose Bids they accompany.

19. Execution of Agreement

The Bidder to whom award is made shall execute a written Agreement with the District on the form of agreement provided, shall secure all insurance, and shall furnish all certificates and bonds required by the Contract Documents within five (5) working days after receipt of Notice of Award from the District. Failure or refusal to enter into an Agreement as herein provided or to conform to any of the stipulated requirements in connection therewith shall be just cause for annulment of the award and forfeiture of the Bid security. If the lowest responsive, responsible Bidder refuses or fails to execute the Agreement, the District may award the Contract to the second lowest responsive, responsible Bidder. If the second lowest responsive, responsible Bidder refuses or fails to execute the Agreement, the District may award the contract to the third lowest responsive, responsible Bidder. On the failure or refusal of such second or third lowest Bidder to execute the Agreement, each such Bidder's Bid securities shall be likewise forfeited to the District.

20. Liquidated Damages

Provisions for liquidated damages, if any, are set forth in the Agreement.

21. Workers' Compensation Requirement

The Bidder should be aware that in accordance with Section 3700 of the California Labor Code it will, if awarded the Contract, be required to secure the payment of compensation to its employees and execute the Workers' Compensation Certification in the form contained in these Contract Documents.

22. Non-Collusion Affidavit

Bidders must execute the non-collusion affidavit contained in these contract documents and submit the same with his/her bid.

23. Materials Suppliers List

Bidders and their subcontractors must complete the List of Materials Suppliers and Material Guarantee form provided with the Bid Forms and must submit the completed form with the Bid.

End of Instructions To Bidders

**This Page Left Intentionally Blank**

# Proposal

To the Noyo Harbor District:

The undersigned declares that he/she has carefully examined the location of the proposed work, that he/she has examined the contract documents, and read the accompanying instructions to bidders, and hereby proposes to do all the work required to complete the said work in accordance with said contract, and special provisions for the unit or lump sum prices set forth in the attached Bid Schedules.

It is understood and agreed that the undersigned shall complete the work of the contract within the time provided for in the Contract Documents governing said work.

If awarded the contract, the undersigned hereby agrees to sign said contract and to furnish the necessary bonds, insurance certificates, and agreements within five (5) working days after receipt of Notice of Award of said contract from the District.

The undersigned has examined the location of the proposed work and is familiar with the contract documents, and the local conditions at the place where the work is to be done.

The undersigned has checked carefully all the figures on the attached Bid Schedule and understands that the District will not be responsible for any errors or omissions by the party of the undersigned in making up the bid.

Enclosed find bidder's bond, certified check, or cashier's check No. \_\_\_\_\_ of the \_\_\_\_\_ (Company) (Bank) for \_\_\_\_\_ Dollars (\$ \_\_\_\_\_).

This project requires a Class A California State Contractor's License.

Contractor's License No. \_\_\_\_\_ License \_\_\_\_\_ Class \_\_\_\_\_

Expiration Date of Contractor's License \_\_\_\_\_

A bid submitted to a public agency by a contractor who is not licensed shall be considered nonresponsive and shall be rejected by the public agency. The undersigned contractor declares that the contractor's license number and expiration date stated herein are made under penalty of perjury under the laws of the State of California.

Contractor: \_\_\_\_\_

Signed by: \_\_\_\_\_

Address: \_\_\_\_\_

Dated this \_\_\_\_\_ day of \_\_\_\_\_, 20\_\_\_\_\_

**This Page Left Intentionally Blank.**



## Bid Schedule

(DO NOT DETACH)

Item No.	Base Bid Item Description With Unit Price Written in Words	Approx. Quantity	Unit Price	Total Item Price
1	Mobilization/Demobilization _____ _____ Dollars	1 LS	\$ _____	\$ _____
2	Provide and Install Erosion and Sediment Control BMPs _____ _____ Dollars	1 LS	\$ _____	\$ _____
3	Site Preparation and Grading _____ _____ Dollars	1 LS	\$ _____	\$ _____
4	Remove and Dispose of Spoils _____ _____ Dollars	1 LS	\$ _____	\$ _____
5	Provide and Install Fish Cleaning Station Concrete Foundation Including Floor Drain _____ _____ Dollars	240 SF	\$ _____	\$ _____
6	Provide and Install Cold Shower Concrete Pad Including Floor Drain _____ _____ Dollars	25 SF	\$ _____	\$ _____
7	Provide and Install Fish Cleaning Station Structure Including Roofing _____ _____ Dollars	1 LS	\$ _____	\$ _____

Item No.	Base Bid Item Description With Unit Price Written in Words	Approx. Quantity	Unit Price	Total Item Price
8	Provide and Install 4" PVC Sanitary Sewer Including Connection to Existing MH _____ _____ Dollars	1 LS	\$ _____	\$ _____
9	Provide and Install ¾" PVC Water Including Connection to Existing PVC Water _____ _____ Dollars	1 LS	\$ _____	\$ _____
10	Provide and Install Noyo Harbor Sign Posts _____ _____ Dollars	1 LS	\$ _____	\$ _____
11	Provide and Install Fish Cleaning Station Primer and Paint _____ _____ Dollars	1 LS	\$ _____	\$ _____
12	Regrade and Reseed Disturbed Area in Grader Park _____ _____ Dollars	1 LS	\$ _____	\$ _____
<b>Total Project Base Bid in Words:</b> _____ _____ Dollars			<b>Total Base Bid in Figures:</b> _____ \$ _____	

Item No.	Bid Alternate Item Description With Unit Price Written in Words	Approx. Quantity	Unit Price	Total Item Price
1	Provide and Install Concrete Sidewalk and Sidewalk Features  _____ Dollars	1000 SF	\$ _____	\$ _____
2	Provide and Install 1" PVC Electrical Conduit with 12 Ga Romex Including Connection to Existing Panel  _____ Dollars	1 LS	\$ _____	\$ _____
<b>Total Project Bid Alternate in Words:</b>			<b>Total Bid Alternate in Figures:</b>	
_____ Dollars			\$ _____	
_____ Dollars			\$ _____	

TOTAL BID PRICE INCLUDING BASE BID AND ALTERNATIVES:

\_\_\_\_\_ \$ \_\_\_\_\_  
(In Words) (In Figures)

\_\_\_\_\_  
Signature of Bidder

\_\_\_\_\_  
Company

Bidder Must Sign This Page  
End of Base Bid Schedule Section

# Non-Collusion Affidavit

To Be Executed By Bidder and Submitted With Bid

The undersigned declares:

I am the \_\_\_\_\_ of \_\_\_\_\_, the party making the foregoing bid.

The bid is not made in the interest of, or on behalf of, any undisclosed person, partnership, company, association, organization, or corporation. The bid is genuine and not collusive or sham. The bidder has not directly or indirectly induced or solicited any other bidder to put in a false or sham bid. The bidder has not directly or indirectly colluded, conspired, connived, or agreed with any bidder or anyone else to put in a sham bid, or to refrain from bidding. The bidder has not in any manner, directly or indirectly, sought by agreement, communication, or conference with anyone to fix the bid price of the bidder or any other bidder, or to fix any overhead, profit, or cost element of the bid price, or of that of any other bidder. All statements contained in the bid are true. The bidder has not, directly or indirectly, submitted his or her bid price or any breakdown thereof, or the contents thereof, or divulged information or data relative thereto, to any corporation, partnership, company, association, organization, bid depository, or to any member or agent thereof, to effectuate a collusive or sham bid, and has not paid, and will not pay, any person or entity for such purpose. Any person executing this declaration on behalf of a bidder that is a corporation, partnership, joint venture, limited liability company, limited liability partnership, or any other entity, hereby represents that he or she has full power to execute, and does execute, this declaration on behalf of the bidder.

I declare under penalty of perjury under the laws of the State of California that the foregoing is true and correct and that this declaration is executed:

on: \_\_\_\_\_ [date],

at: \_\_\_\_\_ [city], \_\_\_\_\_ [state].

End of Non-Collusion Affidavit Form

**This Page Left Intentionally Blank.**

# Questionnaire and Financial Assurance Statement Form

The following statements as to experience and financial qualifications of the Bidder are submitted in conjunction with the proposal as part thereof, and the truthfulness and accuracy of the information is guaranteed by the Bidder.

The Bidder has been engaged in the contracting business under the present business for \_\_\_\_\_ years. Experience in work of a nature similar to that covered in the proposal extends over a period of \_\_\_\_\_ years.

The Bidder, as a contractor, has never failed to complete a contract awarded to contractor satisfactorily, except as follows:

---

---

---

---

List all claims and lawsuits presented or filed in the last five (5) years, regardless of the form, regarding any public works project:

---

---

---

---

The following contracts for work have been completed in the last three (3) years for the persons, firm or authority indicated and to whom reference is made:

<b>Year</b>	<b>Type of Work-Size, Length and Contract Amount</b>	<b>Location and for Whom Performed</b>
_____	_____	_____
_____	_____	_____
_____	_____	_____
_____	_____	_____

The following complaints have been made against the Bidder's contractor's license within the past ten (10) years:

Date: \_\_\_\_\_ Nature of Complaint: \_\_\_\_\_

---

---

Reference is hereby made to the following bank or banks as to the financial responsibility of the bidder:

Name of Bank	Address

Reference is hereby made to the following surety companies as to the financial responsibility and general reliability of the bidder:

Name of Surety Company: \_\_\_\_\_

I, the undersigned, declare under penalty of perjury under the laws of the State of California, that the foregoing is true and correct.

\_\_\_\_\_  
Signature of Bidder

\_\_\_\_\_  
Name of Bidder

End of Questionnaire and Financial Statement Form



## Bid Bond

We, \_\_\_\_\_ as Principal, and \_\_\_\_\_ as Surety, jointly and severally, bind ourselves, our heirs, representatives, successors and assigns, as set forth herein, to the Noyo Harbor District (herein called " Owner") for the payment of the penal sum of \_\_\_\_\_ Dollars (\$ \_\_\_\_\_ ), lawful money of the United States, which is ten (10) percent of the total amount bid by bidder to the Owner. Principal has submitted the accompanying bid for the construction of the \_\_\_\_\_ project.

If the Principal is awarded the contract and enters into a written contract, in the form prescribed by the Owner, at the price designated by his bid, and files the bonds required by the Agreement with the Owner, and carries all insurance in type and amount which conforms to the contract documents and furnishes required certificates and endorsements thereof, then this obligation shall be null and void; otherwise it shall remain in full force and effect.

Forfeiture of this bond, or any deposit made in lieu thereof, shall not preclude the Owner from seeking all other remedies provided by law to cover losses sustained as a result of the Principal's failure to do any of the foregoing.

Principal and Surety agree that if the Owner is required to engage the services of an attorney in connection with the enforcement of this bond, each shall pay the Owner's reasonable attorney's fees, witness fees and other costs incurred with or without suit.

Executed on \_\_\_\_\_, \_\_\_\_\_.

\_\_\_\_\_  
Principal

By: \_\_\_\_\_  
Signature

\_\_\_\_\_  
Title

Any claims under this bond may be addressed to:

\_\_\_\_\_  
\_\_\_\_\_  
\_\_\_\_\_  
\_\_\_\_\_

(Name and address of Surety's agent for service of process in California, if different from above)

(Telephone number of Surety's agent in California)

(Attach Acknowledgment)

\_\_\_\_\_  
Surety

By \_\_\_\_\_  
(Attorney- in-Fact)

**Notice:**

No substitution or revision to this bond form will be accepted. Be sure that all bonds submitted have a certified copy of the bonding agent's power of attorney attached. Also verify that Surety is an "Admitted Surety" (i.e., qualified to do business in California), and attach proof of verification (website printout from the California Department of insurance website [<http://www.insurance.ca.gov/docs/index.html>] or certificate from County Clerk).

End of Bid Bond

(Do Not Detach)

## Performance Bond

KNOW ALL MEN BY THESE PRESENTS: That WHEREAS, the Noyo Harbor District, Fort Bragg, County of Mendocino, State of California, by motion passed \_\_\_\_\_, 20\_\_\_\_, has awarded to \_\_\_\_\_, hereinafter designated as the "Principal," a contract for constructing

### Noyo Harbor Fish Cleaning Station

AND WHEREAS, said Principal is required under the terms of said contract to furnish a bond for the faithful performance of said contract,

NOW THEREFORE, we,

\_\_\_\_\_

as Principal, and \_\_\_\_\_,  
as Surety, are held and firmly bound unto the Noyo Harbor District, Fort Bragg, County of Mendocino, State of California, hereinafter called the "Owner," to the penal sum of \_\_\_\_\_ Dollars (\$ \_\_\_\_\_) lawful money of the United States of America, for which sum well and duly to be made, we bind ourselves, our heirs, executors, administrators, and successors, jointly and severally, firmly by these presents.

THE CONDITION OF THIS OBLIGATION IS SUCH, that if the hereby bound Principal, his/her or its heirs, executors, administrators, successors, or assigns shall in all things stand to and abide by and well and truly keep and perform all the undertakings, terms, covenants, conditions, and agreements in the said contract and any alteration thereof, made as therein provided, all within the time and in the manner therein designated and in all respects according to their true intent and meaning, then this obligation shall become null and void; otherwise it shall be and remain in full force and virtue.

FURTHER, THE SAID SURETY, FOR VALUE RECEIVED, HEREBY STIPULATES AND AGREES that no change, extension of time, or alteration or modification of the Contract Documents or of the work to be performed thereunder, shall in any way affect its obligations on this bond, and it does hereby waive notice of any such change, extension of time, alteration, or modification of the Contract Documents or of work to be performed thereunder.

**(Do Not Detach)**

IN WITNESS WHEREOF, five (5) identical counterparts of this instrument, each of which shall for all purposes be deemed an original thereof, have been duly executed by Principal and

Surety herein named, on the \_\_\_\_\_ day of \_\_\_\_\_, 20\_\_\_\_\_, the name and corporate seal of each corporate party being hereto affixed, and these presents duly signed by its undersigned representative pursuant to authority of its governing body.

\_\_\_\_\_  
Principal

By \_\_\_\_\_

\_\_\_\_\_  
Title

\_\_\_\_\_  
Surety

By \_\_\_\_\_

\_\_\_\_\_  
\_\_\_\_\_  
Address of Surety

(Do Not Detach)

## Payment/Labor and Materials Bond

KNOW ALL MEN BY THERE PRESENTS: That WHEREAS, the Noyo Harbor District, Fort Bragg, County of Mendocino, State of California, by motion passes \_\_\_\_\_, 20\_\_, has awarded to \_\_\_\_\_, hereinafter designated as the "PRINCIPAL" a contract constructing:

### Noyo Harbor Fish Cleaning Station

AND WHEREAS, said Principal is required under the terms of said contract to furnish a bond in connection with said contract, providing that if said Principal, or any of his or its subcontractors, shall fail to pay for any materials, provision, provender, or other supplies or teams used in, upon, or about the performance of the work contracted to be done or for any work or labor done thereon of any kind, the Surety on this bond will pay the same to the extent hereinafter set forth;

WHEREAS, pursuant to California Civil Code Section 3247, the PRINCIPAL is required, before entering upon the performance of the Contract, to file a payment bond with and have such bond approved by the officer or public entity by whom the Contract is awarded; and

WHEREAS, pursuant to California Civil Code Section 3248, such payment bond must be in a sum not less than one hundred percent (100%) of the total amount payable by the terms of the Contract, and must satisfy the other requirements specified in that section; and

WHEREAS, the PRINCIPAL is required in accordance with the Contract to furnish a payment bond in connection with the Contract to secure payment of claims of laborers, mechanics and materialmen employed on work under the Contract in accordance with applicable law;

NOW, THEREFORE, THESE PRESENTS WITNESSETH:

That the PRINCIPAL and the undersigned \_\_\_\_\_, as surety (designated as "SURETY"), an admitted surety insurer authorized to do business in the State of California are held and firmly bound unto all laborers, material men, and all other persons named in California Civil Code Section 3181 in the sum of \_\_\_\_\_ Dollars (\$ \_\_\_\_\_), lawful money of the United States, being a sum not less than one hundred percent of the total amount payable by the terms of the Contract, for the payment of which sum well and truly to be made, we bind ourselves, our heirs, executors, administrators, successors, or assigns, jointly and severally, by these presents.

THE CONDITION OF THIS OBLIGATION IS SUCH that if the PRINCIPAL or any of the PRINCIPAL's subcontractors, or the heirs, executors, administrators, successors, or assigns of any, all, or either of them, shall fail to pay any persons named in California Civil Code Section 3181, or fail to pay for any labor, materials, provisions, provender, or other supplies used in, upon, for or about the performance of the work contracted to be done, or for any work or labor thereon of any kind, or fail to pay amounts due under the Unemployment Insurance Code with respect to such work or labor, or fail to pay for any amounts required to be deducted, withheld, and paid over to the Employment Development Department from the wages of employees of the PRINCIPAL or any subcontractors of the PRINCIPAL pursuant to Section 13020 of the Unemployment Insurance Code with respect to such work or labor, that the SURETY will pay for the same in an amount not exceeding the amount herein above set forth, and also, in case suit is brought upon this

bond, will pay a reasonable attorney's fee to be awarded and fixed by the Court; otherwise this obligation shall be void.

It is hereby expressly stipulated and agreed by the said Surety, for value received, that this bond shall inure to the benefit of any and all of the persons named in Section 3181 of the California Civil Code so as to give a right of action to them or their assigns in any suit brought upon this bond.

It is hereby further expressly stipulated and agreed by the said Surety, for value received, that no change, extension of time, alteration or addition to the terms of the Contract or the Specifications or drawings accompanying the same or to any other part of the contract documents, as defined therein, shall in any manner affect the obligations of the SURETY on this bond, and SURETY does hereby waive notice of any such change, extension, alteration, or addition.

IN WITNESS WHEREOF, the above-bound parties have executed this instrument under their several seals this \_\_\_\_\_ day of \_\_\_\_\_, 2022, the name and corporate seals of each corporate party being hereto affixed and these presents duly signed by their undersigned representatives, pursuant to authority of their governing bodies.

(Corporate Seal)

PRINCIPAL

By: \_\_\_\_\_

(Acknowledgement)

Title: \_\_\_\_\_

(Corporate Seal)

SURETY

By: \_\_\_\_\_

(Attorney-in-fact)

(Acknowledgement)

Title: \_\_\_\_\_

*(NOTE TO SURETY COMPANY: A certified copy of unrevoked resolution of authority for the attorney-in-fact must be submitted with and attached to the executed bid bond.)*

## **List of Subcontractors**

In accordance with the provisions of Sections 4100-4114, inclusive, of the Public Contract Code of the State of California, each bidder shall list below the name and location of place of business of each subcontractor who will perform a portion of the contract work in an amount in excess of one-half of one percent (0.5%) of the total contract price. In each such instance, the nature and extent of the work to be performed shall be described.

If a prime contractor fails to specify a subcontractor or if a prime contractor specifies more than one (1) subcontractor for the same portion of work to be performed under the contract in excess of one-half of one percent (0.5%) of the prime contractor's total bid, the prime contractor agrees that he or she is fully qualified to perform that portion himself or herself, and that the prime contractor shall perform that portion himself or herself. The subcontracting of work for which no subcontractor was designated in the original bid and which is in excess of one-half of one percent (0.5%) of the total contract price, will be allowed only with the written consent of the District.

<b>Name of Subcontractor</b>	<b>Address of Office, Mill, or Shop</b>	<b>Description of Work to be Performed (Also Show Bid Schedule Item Number)</b>

End of List of Subcontractors

**This Page Left Intentionally Blank**



# Bid Proposal Certificate

State of California (if Corporation)

) ss:  
County of \_\_\_\_\_)

I Hereby Certify that a meeting of the Board of Directors of the \_\_\_\_\_

\_\_\_\_\_ a Corporation existing  
under the laws of the State of \_\_\_\_\_, held on \_\_\_\_\_,  
20\_\_\_\_\_, the following resolution was duly passed and adopted:

"Resolved, that \_\_\_\_\_, as President of the corporation, be and is hereby  
authorized to execute the Bid Proposal dated \_\_\_\_\_, 20\_\_\_\_\_, for the  
\_\_\_\_\_ project, in the Noyo Harbor District, and that  
his/her execution thereof, attested by the Secretary of the Corporation, and with the Corporate Seal affixed,  
shall be the official act and deed of this Corporation."

I further certify that said resolution is now in full force and effect.

In Witness Whereof, I have hereunto set my hand and affixed the official seal of the corporation this \_\_\_\_\_,  
day of \_\_\_\_\_, 20\_\_\_\_\_

\_\_\_\_\_  
Secretary

(SEAL)

# Assurances for Compliance with Federal Laws and Regulations

The Contractor is required to comply with the following federal laws and regulations:

- Non-discrimination in Employment in accordance with Executive Order 11246 of September 24, 1965 entitled "Equal Employment Opportunity" as amended by Executive Order 11375 of October 13, 1967
- Debarment in accordance with the Executive Order 12549 and Executive Order 1 U46
- Anti-kickback in accordance with the Copeland "Anti-Kickback" Act (18 U.S.C. 874)
- Contract Work Hours and Safety Standards in accordance with Sections 103 and 107 of the Contract Work Hours and Safety Standards Act (40 U.S.C.327-330)

I do solemnly declare and affirm that I am obligated to comply with the above Federal laws and regulations. It is understood that non-compliance with any one of the above Federal laws and regulations will be sufficient reason to cause termination of the contract.

\_\_\_\_\_  
Signature of Prime Contractor

\_\_\_\_\_  
Date

\_\_\_\_\_  
Print Name and Title

**This Page Left Intentionally Blank.**

## Equal Employment Opportunity Certification

The Bidder \_\_\_\_\_, proposed

Subcontractor \_\_\_\_\_, hereby certifies that he/she  has/ has not participated in a previous contract or subcontract subject to the equal opportunity clauses, as required by Executive Orders 10925, 11114, or 11246, and that, where required, he/she has filed with the Joint Reporting Committee, the Director of the Office of Federal Contract Compliance, a Federal Government contracting or administering agency, or the former President's Committee on Equal Employment Opportunity, all reports due under the applicable filing requirements.

Note: The above certification is required by the Equal Employment Opportunity Regulations of the Secretary of Labor (41 CFR 60-1.7(b) (1)), and must be submitted by bidders and proposed subcontractors only in connection with contracts and subcontracts, which are subject to the Equal Opportunity clause. Contracts and subcontracts which are exempt from the Equal Opportunity clause are set forth in 41 CFR 60-1.5. (Generally, only contracts or subcontracts of \$10,000 or under are exempt.)

Currently, Standard Form 100 (EEO-1) is the only report required by the Executive Orders or their implementing regulations.

Proposed prime contractors and subcontractors who have participated in a previous contract or subcontract subject to the Executive Orders and have not filed the required reports should note that 41 CFR 60-1. 7(b) (1) prevents the award of contracts and subcontracts unless such contractor submits a report covering the delinquent period or such other period specified by the Federal Highway Administration or by the Director, Office of Federal Contract Compliance, U.S. Department of Labor.

**This Page Left Intentionally Blank.**

# Debarment and Suspension Certification

## Title 49, Code of Federal Regulations, Part 29

The bidder, under penalty of perjury, certifies that, except as noted below, he/she or any other person associated therewith in the capacity of owner, partner, director, officer, and manager:

- Is not currently under suspension, debarment, voluntary exclusion, or determination of ineligibility by any federal agency;
- Has not been suspended, debarred, voluntarily excluded or determined ineligible by any federal agency within the past 3 years;
- Does not have a proposed debarment pending; and
- Has not been indicted, convicted, or had a civil judgment rendered against it by a court of competent jurisdiction in any matter involving fraud or official misconduct within the past 3 years.

If there are any exceptions to this certification, insert the exceptions in the following space.

Exceptions will not necessarily result in denial of award, but will be considered in determining bidder responsibility. For any exception noted above, indicate below to whom it applies, initiating agency, and dates of action.

**Notes:** Providing false information may result in criminal prosecution or administrative sanctions. The above certification is part of the Proposal. Signing this Proposal on the signature portion thereof shall also constitute signature of this Certification.

**This Page Left Intentionally Blank.**

## Nonlobbying Certification For Federal-Aid Contracts

The prospective participant certifies, by signing and submitting this bid or proposal, to the best of his or her knowledge and belief, that:

- 1) No federal appropriated funds have been paid or will be paid, by or on behalf of the undersigned, to any person for influencing or attempting to influence an officer or employee of any federal agency, a Member of Congress, an officer or employee of Congress, or an employee of a Member of Congress in connection with the awarding of any Federal contract, the making of any federal grant, the making of any federal loan, the entering into of any cooperative agreement, and the extension, continuation, renewal, amendment, or modification of any federal contract, grant, loan, or cooperative agreement.
- 2) If any funds other than federal appropriated funds have been paid or will be paid to any person for influencing or attempting to influence an officer or employee of any federal agency, a Member of Congress, an officer or employee of Congress, or an employee of a Member of Congress in connection with this federal contract, grant, loan, or cooperative agreement, the undersigned shall complete and submit Standard Form-LLL, "Disclosure of Lobbying Activities," in accordance with its instructions.

This certification is a material representation of fact upon which reliance was placed when this transaction was made or entered into. Submission of this certification is a prerequisite for making or entering into this transaction imposed by Section 1352, Title 31, U.S. Code. Any person who fails to file the required certification shall be subject to a civil penalty of not less than \$10,000 and not more than \$100,000 for each such failure.

The prospective participant also agrees by submitting his or her bid or proposal that he or she shall require that the language of this certification be included in all lower tier subcontracts, which exceed \$100,000 and that all such sub-recipients shall certify and disclose accordingly.



**This Page Left Intentionally Blank.**

# Disclosure of Lobbying Activities

Complete this form to disclose lobbying activities pursuant to 31 USC 1352

<p><b>1. Type of Federal Action</b></p> <p><input type="checkbox"/> a. contract</p> <p><input type="checkbox"/> b. grant</p> <p><input type="checkbox"/> c. cooperative agreement</p> <p><input type="checkbox"/> d. loan</p> <p><input type="checkbox"/> e. loan guarantee</p> <p><input type="checkbox"/> f. loan insurance</p>	<p><b>2. Status of Federal Action:</b></p> <p><input type="checkbox"/> a. bid/offer/application</p> <p><input type="checkbox"/> b. initial award</p> <p><input type="checkbox"/> c. post-award</p>	<p><b>3. Report Type:</b></p> <p><input type="checkbox"/> a. initial</p> <p><input type="checkbox"/> b. material change</p> <p style="text-align: center;">For Material Change Only:</p> <p style="text-align: center;">Year _____ Quarter _____</p>
<p><b>4. Name and Address of Reporting Entity</b></p> <p><input type="checkbox"/> Prime <span style="margin-left: 150px;"><input type="checkbox"/> Subawardee</span></p> <p style="text-align: center;">Tier _____, if known</p> <p style="text-align: center;">_____</p> <p style="text-align: center;">Congressional District, if known</p>	<p><b>5. If Reporting Entity in No. 4 is Subawardee, Enter Name and Address of Prime:</b></p> <p style="text-align: center;">_____</p> <p style="text-align: center;">Congressional District, if known</p>	
<p><b>6. Federal Department/Agency</b></p> <p>_____</p>	<p><b>7. Federal Program Name/Description</b></p> <p>_____</p> <p style="text-align: right;">CFDA Number, if Applicable _____</p>	
<p><b>8. Federal Action Number, if known:</b></p> <p>_____</p>	<p><b>9. Award Amount, if known:</b></p> <p>_____</p>	
<p><b>10. a. Name and Address of Lobby Entity</b> (if individual, last name, first name, MI)</p> <p>_____</p>	<p><b>b. Individuals Performing Services (including address if different from No. 10a)</b> (last name, first name, MI)</p> <p>_____</p>	
<p style="text-align: center;">(attach Continuation Sheet(s) if necessary)</p> <p><b>11. Amount of Payment (check all that apply)</b></p> <p>\$ _____ <input type="checkbox"/> actual <input type="checkbox"/> planned</p>	<p><b>13. Type of Payment (check all that apply)</b></p> <p><input type="checkbox"/> a. retainer</p> <p><input type="checkbox"/> b. on-time fee</p> <p><input type="checkbox"/> c. commission</p> <p><input type="checkbox"/> d. contingent fee</p> <p><input type="checkbox"/> e. deferred</p> <p><input type="checkbox"/> f. other, specify: _____</p>	
<p><b>12. Form of Payment (check all that apply)</b></p> <p><input type="checkbox"/> a. cash</p> <p><input type="checkbox"/> b. i-kind: specify: nature _____</p> <p style="text-align: right;">value _____</p>		
<p><b>14. Brief Description of Services Performed or to be performed and Date(s) of service, including officer(s), employee(s), or member(s) contacted, for Payment Indicated in Item 11:</b></p> <p>_____</p> <p style="text-align: center;">(attach Continuation Sheet(s) if necessary)</p>		
<p><b>15. Continuation Sheet(s) attached:</b> <input type="checkbox"/> Yes <input type="checkbox"/> No</p>		
<p><b>16. Information requested through this form is authorized by Title 31 U.S.C. Section 1352.</b> This disclosure of lobbying reliance was placed by the tier above when his transaction was made or entered into. This disclosure is required pursuant to 31 U.S.C. 1352. This information will be reported to Congress semiannually and will be available for public inspection. Any person who fails to file the required disclosure shall be subject to a civil penalty of not less than \$10,000 and not more than \$100,000 for each such failure.</p>		
		<p>Signature: _____</p> <p>Print Name: _____</p> <p>Title: _____</p> <p>Telephone No.: _____ Date: _____</p>

Authorized for Local Reproduction  
Standard Form - LLL

**For Federal use Only:**

## Instructions for Completion of SF-LLL, Disclosure of Lobbying Activities

This disclosure form shall be completed by the reporting entity, whether subawardee or prime federal recipient, at the initiation or receipt of covered federal action or a material change to previous filing pursuant to title 31 U.S .C. Section 1352. The filing of a form is required for such payment or agreement to make payment to lobbying entity for influencing or attempting to influence an officer or employee of any agency, a Member of Congress an officer, or employee of Congress or an employee of a Member of Congress in connection with a covered Federal action. Attach a continuation sheet for additional information if the space on the form is inadequate. Complete all items that apply for both the initial filing and material change report. Refer to the implementing guidance published by the Office of Management and Budget for additional information.

1. Identify the type of covered federal action for which lobbying activity is and/or has been secured to influence, the outcome of a covered federal action.
2. Identify the status of the covered federal action.
3. Identify the appropriate classification of this report. If this is a follow-up report caused by a material change to the information previously reported, enter the year and quarter in which the change occurred. Enter the date of the last, previously submitted report by this reporting entity for this covered federal action.
4. Enter the full name, address, city, State, and zip code of the reporting entity. Include Congressional District if known. Check the appropriate classification of the reporting entity that designates if it is or expects to be a prime or subaward recipient. Identify the tier of the subawardee, e.g., the first sub-awardee of the prime is the first tier. Sub-awards include but are not limited to subcontracts, sub grants, and contract awards under grants.
5. If the organization filing the report in Item 4 checks "Subawardee" then enter the full name, address, city, State and zip code of the prime federal recipient. Include Congressional District, if known.
6. Enter the name of the federal agency making the award or loan commitment. Include at least one organization level below agency name, if known. For example, Department of Transportation, United States Coast Guard.
7. Enter the federal program name or description of the covered federal action (item 1). If known, enter the full Catalog of Federal Domestic Assistance (CFDA) number for grants, cooperative agreements, loans, and loan commitments.
8. Enter the most appropriate federal identifying number available for the federal action identification in item 1 (e.g., Request for Proposal (RFP) number, Invitation for Bid (IFB) number, grant announcement number, the contract grant., or loan award number, the application/proposal control number assigned by the federal agency). Include prefixes, e.g., "RFP-DE-90-001."
9. For a covered federal action where there has been an award or loan commitment by the Federal agency, enter the federal amount of the award/loan commitments for the prime entity identified in item 4 or 5.
10. (a) Enter the full name, address, city, State, and zip code of the lobbying entity engaged by the reporting entity identified in item 4 to influence the covered federal action.

(b) Enter the full names of the individual(s) performing services and include full address if different from 10 (a). Enter Last Name, First Name, and Middle Initial (MI).

11. Enter the amount of compensation paid or reasonably expected to be paid by the reporting entity (item 4) to the lobbying entity (item 10). Indicate whether the payment has been made (actual) or will be made (planned). Check all boxes that apply. If this is a material change report, enter the cumulative amount of payment made or planned to be made.
12. Check the appropriate box (es). Check all boxes that apply. If payment is made through an in-kind contribution, specify the nature and value of the in-kind payment.
13. Check the appropriate box (es). Check all boxes that apply. If other, specify nature.
14. Provide a specific and detailed description of the services that the lobbyist has performed or will be expected to perform and the date(s) of any services rendered. Include all preparatory and related activity not just time spent in actual contact with federal officials. Identify the federal officer(s) or employee(s) contacted or the officer(s) employee(s) or Member(s) of Congress that were contacted.
15. Check whether or not a continuation sheet(s) is attached.
16. The certifying official shall sign and date the form; print his/her name title and telephone number.

Public reporting burden for this collection of information is estimated to average 30 minutes per response, including time for reviewing instruction, searching existing data sources, gathering and maintaining the data needed, and completing and reviewing the collection of information. Send comments regarding the burden estimate or any other aspect of this collection of information, including suggestions for reducing this burden, to the Office of Management and Budget, Paperwork Reduction Project (0348-0046), Washington, D.C. 20503. SF-LLL-instructions Rev. 06-04-90«ENDIF»

**This Page Left Intentionally Blank.**

**Construction Agreement**  
**FISH CLEANING STATION PROJECT**

**Noyo Harbor District**  
**Fort Bragg, California**

**This Page Left Intentionally Blank.**

# Table of Contents

	Page
<b>Section IV: Construction Agreement</b>	
Article 1: Work .....	CA-1
Article 2: Completion of Work .....	CA-1
Article 3: Liquidated Damages .....	CA-1
Article 4: Prevailing Wages .....	CA-2
Article 5: Contract Price .....	CA-3
Article 6: Bonds .....	CA-3
Article 7: Payment Procedures .....	CA-3
Article 8: Retention .....	CA-4
Article 9: Contract Documents.....	CA-4
Article 10: Insurance .....	CA-6
Article 11: Indemnification.....	CA-9
Article 12: Disclaimer and Indemnity Concerning Labor Code Section 6400 .....	CA-10
Article 13: Independent Contractor.....	CA-11
Article 14: Subcontractors .....	CA-11
Article 15: Compliance with Laws/Provisions .....	CA-11
Article 16: Notices.....	CA-15
Article 17: Governing Law/Venue .....	CA-16
Article 18: Non-Waiver.....	CA-16
Article 19: Third Party Beneficiaries.....	CA-16
Article 20: Assignment .....	CA-17
Article 21: Severability .....	CA-17
Article 22: Attorney’s Fees.....	CA-17
Article 23: Sole and Only Agreement.....	CA-17
Agreement Certificate.....	CA-20
Agreement Certificate.....	CA-22
Agreement Certificate.....	CA-24



**This Page Left Intentionally Blank.**

## **Agreement**

This Agreement is dated as of the \_\_\_\_ day of \_\_\_\_\_ in the year 20\_\_\_\_, by and between Noyo Harbor District (hereinafter called "District" and \_\_\_\_\_ called "Contractor").

District and Contractor, in consideration of the mutual covenants hereinafter set forth, agree as follows:

### **Article 1: Work**

Contractor shall complete the Work as specified or indicated in the District's Contract Documents entitled Noyo Harbor District Fish Cleaning Station Project. Quality control shall be performed and compliance with the Contract shall be verified by qualified professionals selected by the District or the District's representative.

To include the performance of all the work and the furnishing of all the labor, supplies, tools, and equipment to construct a new covered fish cleaning station, extension of concrete sidewalk, new post and rope fencing adjacent to proposed sidewalks along the riverbank, new "Caught from Noyo Harbor" bulletin board sign, new cold-water shower, connections to utilities including water, sewer, and stormwater.

Contractor has had an opportunity to thoroughly inspect the subject matter of this agreement. Contractor accepts the Work and is satisfied that it can complete the Work for the contract price. District shall be responsible for obtaining all required permits prior to Work commencing by Contractor.

Contractor is aware that the project is funded by the American Rescue Plan Act through the California State Lands Commission, and funding agency may at any and all reasonable times during the term of this Agreement, enter the Project area for purposes of inspecting the Project area and have the right to review the Contractor's records.

### **Article 2: Completion of Work**

The Work shall be completed to the satisfaction of the District within **30 DAYS** from the commencement date stated in the Notice to Proceed. In no event, however, shall the Work to be performed under this contract be considered to be complete until all construction items called for as stated in *Article 1: Work* has been completed and the contract price paid in full.

### **Article 3: Liquidated Damages**

- A. District and the Contractor recognize that time is of the essence of this Agreement and that the District will suffer financial loss if the Work is not completed within the time specified in Article 2 herein, plus any extensions thereof allowed in accordance with Article 12 of the General Conditions. It is hereby understood and agreed that it is and will be difficult and/or impossible to ascertain and determine the actual damage which the District will sustain in the event of and by reason of the Contractor's failure to fully perform the Work or to fully perform all of its contract obligations that have accrued by the time for completion as specified in Article 2 herein and/or as specified for completion of any scheduled operations or works described in the Special Provisions. It is, therefore, agreed in accordance with California Government Code Section 53069.85 that the Contractor will forfeit and pay to the District liquidated damages in the sum of One Thousand Dollars (\$1,000) per day for each

and every calendar day that expires after the time for completion specified in Article 2 herein and/or as specified for completion of any scheduled operations or works described in the Special Provisions except as otherwise provided by extension of time pursuant to Article 12 of the General Conditions. It is further understood and agreed in accordance with California Government Code Section 53069.85 that the liquidated damages sum specified in this provision is not manifestly unreasonable under the circumstances existing at the time this contract was made, and that the District may deduct liquidated damages sums in accordance with this provision from any payments due or that may become due the Contractor.

- B. Liquidated damages will continue to accrue at the stated rate until final completion of the Work. Accrued liquidated damages may be deducted by the District from amounts due or that become due to the Contractor for performance of the Work. Liquidated damages may not be waived or reduced by District unless expressly waived or reduced in writing by the Construction Manager.

#### **Article 4: Prevailing Wages**

- A. Pursuant to California Labor Code Section 1771, Contractor and any subcontractor shall pay all workers employed in execution of the Work in accordance with the general rate of per diem wages specified for each craft, classification, or type of worker needed to execute the Work.
- B. Contractor is required to pay all applicable penalties and back wages in the event of violation of prevailing wage law, and Contractor and any subcontractor shall fully comply with California Labor Code Section 1775, which is incorporated by this reference as though fully set forth herein.
- C. Contractor and any subcontractor shall maintain and make available for inspection payroll records as required by California Labor Code Section 1776, which is incorporated by this reference as though fully set forth herein. Contractor is responsible for ensuring compliance with this section.
- D. Contractor and any subcontractor shall fully comply with California Labor Code Section 1777.5, concerning apprentices, which is incorporated by this reference as though fully set forth herein. Contractor is responsible for ensuring compliance with this section.
- E. In accordance with California Labor Code Section 1810, eight (8) hours of labor in performance of the Work shall constitute a legal day's work under this Agreement. Contractor and any subcontractor shall pay workers overtime pay as required by California Labor Code Section 1815. Contractor and any subcontractor shall, as a penalty to the District, forfeit twenty-five dollars (\$25) for each worker employed in the execution of the contract by the respective contractor or subcontractor for each calendar day during which the worker is required or permitted to work more than 8 hours in any one calendar day and 40 hours in any one calendar week in violation so the provisions of Article 3 of Chapter 1 of Part 7, Division 2 of the California Labor Code, which is incorporated by this reference as though fully set forth herein.

## Article 5: Contract Price

- A. District shall pay Contractor for completion of the Work the sum of \_\_\_\_\_ (\$), based on the bid price of same and in accordance with the Contract Documents.
- B. Notwithstanding any provisions herein, Contractor shall not be paid any compensation until such time as Contractor has on file with the District current information requested on the "Vendor Information" form available from the District.
- C. In no case shall the total contract compensation exceed \_\_\_\_\_ (\$) without prior written authorization by the Harbormaster. Further, no compensation for a section or work program component attached with a specific budget shall be exceeded without the prior written authorization of the Harbormaster.

## Article 6: Bonds

- A. Before entering upon the performance of the Work, the Noyo Harbor District shall cause the Contractor to furnish Performance, and Payment/Labor and Materials Bonds, each in the amount of one hundred percent (100%) of the contract price. These Bonds shall remain in effect at least until one (1) year after the date of Completion, except as otherwise provided by Law or Regulation or by the Contract Documents.
- B. The form of the Performance, Payment/Labor and Materials are provided by the District as part of the Contract Documents. Only such bond forms provided by the District are acceptable, and shall be executed by such sureties as are named in the current list of "Companies Holding Certificates of Authority as Acceptable Sureties on Federal bonds and as Acceptable Reinsuring Companies" as published in Circular 570 (amended) by the Audit Staff, Bureau of Government Financial Operations, U.S. Treasury Department. All Bonds signed by an agent must be accompanied by a certified copy of such agent's authority to act.
- C. If the surety on any Bond furnished by the Contractor is declared a bankrupt or becomes insolvent or its right to do business is terminated in any state where any part of the Work is located, the Contractor shall within 7 days thereafter substitute another Bond and surety, which must be acceptable to the District.
- D. All Bonds required by the Contract Documents to be purchased and maintained by Contractor shall be obtained from surety companies that are duly licensed or authorized in the State of California to issue Bonds for the limits so required.

## Article 7: Payment Procedures

Contractor shall submit Applications for Payment in accordance with Article 14 of the General Conditions. Applications for Payment will be processed by the Construction Manager as provided in the General Conditions.

## Article 8: Retention

- A. Pursuant to Section 22300 of the California Public Contract Code, the Contractor may substitute securities for any money withheld by the District to ensure performance under the Contract. At the request and expense of the Contractor, securities equivalent to the amount withheld shall be deposited with the District or with a state or federally chartered bank in California as to the escrow agent, who shall return such securities to the Contractor upon satisfactory completion of the Contract.
- B. Alternatively, the Contractor may request and the District shall make payment of retentions earned directly to the escrow agent at the expense of the Contractor. At the expense of the Contractor, the Contractor may direct the investment of the payments into securities and the Contractor shall receive the interest earned on the investments upon the same terms provided for in this section for securities deposited by the Contractor. The Contractor shall be responsible for paying all fees for the expenses incurred by the escrow account and all expenses of the District. These expenses and payment terms shall be determined by the District's Finance Director or his/her designee and the escrow agent. Upon satisfactory completion of the Contract, the Contractor shall receive from the escrow agent all securities, interest, and payments received by the escrow agent from the District, pursuant to the terms of this section. The Contractor shall pay to each subcontractor, not later than 20 days of receipt of the payment, the respective amount of interest earned, net of costs attributed to retention withheld from each subcontractor, on the amount of retention withheld to ensure the performance of the Contractor.
- C. Securities eligible for investment under Section 22300 shall be limited to those listed in Section 16430 of the Government Code and to bank or savings and loan certificates of deposit, interest-bearing demand deposit accounts, standby letters of credit, or any other security mutually agreed to by the Contractor and the District.

## Article 9: Contract Documents

The Contract Documents which comprise the entire agreement between the District and the Contractor concerning the Work consist of this Agreement and the following attachments to this Agreement:

- Notice Inviting Bids
- Instructions to Bidders
- Bid Forms including the Bid, Bid Schedule(s), Information Required of Bidder, Bid Bond, and all required certificates and affidavits
- Labor and Materials Bond
- Performance Bond
- General Conditions
- Supplementary General Conditions (if any)
- Special Provisions
- Addenda (if any)

- Change Orders which may be delivered or issued after Effective Date of the Agreement and are not attached hereto.

There are no Contract Documents other than those listed in this Article 9. The Contract Documents may only be amended by Change Order as provided in Paragraph 3.5 of the General Conditions.

### **Article 10: Changes in Work**

**Owner Directed Change Orders.** The Owner may at any time during the progress of the Work direct any amendments to the Work or any of the Contract Documents, including, but not limited to the Technical Specifications, or Project Plans. Such amendments will in no way void the agreement, but will be applied to amend the Contract Price, if such amendments affect the Contract Price, the Project schedule, if such amendments affect the Project schedule, or any other provision of the Contract Documents based on a fair and reasonable valuation of the amendment in accordance with this Article.

**Writing Requirement.** Change orders and other amendments to the Contract Documents may be made only by writing executed by authorized representatives of the Owner and the Contractor.

**Contractor Proposed Change Orders.** Unless the Construction Manager otherwise authorizes or the Owner and the Contractor otherwise agree, change order proposals submitted by the Contractor must be submitted to the District and Construction Manager no later than the time of the proposed change.

**All Change Orders.** All change order proposals must be submitted on completed Change Order forms provided by the Owner. All such change order proposals must itemize all cost impacts of the proposed change order and include a total price for that change order and the amended Contract Price that would become effective upon execution of the change order. All change order proposals must specify any change in the Project schedule, or in any project milestone including, but not limited to, the Time for Completion, under the change order. It is understood that change orders that do not specify a change in any milestone, including, but not limited to, the Time for Completion, may be accomplished by the Time for Completion then in effect.

**Change Order Pricing.** Change order pricing will be governed by the following:

- Unit prices specified in the Contract Documents will apply to cost impacts involving items for which the Contract Documents specify unit prices.
- Cost impacts involving items for which no unit prices are specified will be calculated by adding the itemized actual direct cost that would be added or reduced under the change order and an allowance for indirect costs in accordance with this Section. Itemization for direct costs for required labor must include the classifications of labor required, the total hours required for each classification, the hourly rate for each classification and other labor related costs such as liability and workers compensation insurance, social security, retirement and unemployment insurance. All other cost impacts for which no unit prices are specified must be itemized as appropriate, including the cost of tools, vehicles, phones and other equipment, and the cost of all required materials or supplies. Indirect costs added under a change order may not exceed an allowance of fifteen (15) percent of the total of combined Contractor and subcontractor direct costs added under the change order. Such allowance covers Contractor overhead and profit under the change order and includes the cost of insurance in addition to that required pursuant to Section 8.8, bond premiums, superintendent labor, clerical labor, home office expenses, worksite office expenses, and utility costs under the change order. Such costs may not be itemized as direct costs under a change order.

Indirect costs deducted under a change order will be calculated in exactly the same way as indirect costs added under a change order, except indirect costs deducted under a change order may not exceed an allowance of seven and a half (7.5) percent of the total of combined Contractor and subcontractor direct costs deducted under the change order.

**Liability Under Unapproved Change Orders.** The Contractor shall be solely responsible for any and all losses, costs, or liabilities of any kind incurred by the Contractor, any subcontractor engaged in the performance of the Work, any party supplying material or equipment for the Work or any third party that are incurred pursuant to Contractor-proposed change orders prior to issuance of an approved change order executed in accordance with this Section 3. The Contractor will have all of the obligations and the Owner will have all of the rights and remedies that are specified in Section 11 concerning any work or resulting losses, costs, or liabilities pursuant to a Contractor proposed change order before issuance of an approved change order executed in accordance with this Section 3.

**Changes Subject to Contract Documents.** Any changes in the Work and/or the Contract Documents pursuant to change orders and any other amendments issued in accordance with the Contract Documents, including this Section 4, will in all respects be subject to all provisions of the Contract Documents, except as modified by such change orders or amendments.

**Disputed District Directed Change Orders.** If the Contractor disputes an Owner directed change order following a reasonable effort by the and the Contractor to resolve the dispute including, at a minimum, a meeting between appropriate representatives of the Contractor and the Owner, the Contractor must commence performing the Work consistent with the disputed change order within five (5) working days of the last meeting between representatives of the Contractor and the Owner to resolve the dispute, or within the time specified in the disputed District directed change order, whichever is later. In performing Work consistent with a disputed Owner-directed change order pursuant to this provision the Contractor will have all of the Contractor's rights concerning claims pursuant to the Contract Documents and applicable law.

**Disputed Contractor Proposed Change Orders.** If the Owner disputes a Contractor proposed change order, the Owner and the Contractor will use reasonable efforts to resolve the dispute including, at a minimum, holding a meeting between appropriate representatives of the Contractor and the Owner. Regardless of and throughout any such efforts to resolve the dispute the Contractor must continue performing the Work irrespective of and unmodified by the disputed change order. In continuing to perform the Work, the Contractor will retain all of the Contractor's rights under contract or law pertaining to resolution of disputes and protests between contracting parties. Disputes between the Owner and the Contractor concerning any Contractor-proposed change order or other amendment do not excuse the Contractor's obligation to perform the Work in accordance with the Contract Documents excluding such Contractor-proposed change order or other amendment by the Time for Completion or waive any other Project milestone or other requirement of the Contract Documents.

## **Article 11: Insurance**

Contractor and any subcontractor shall not commence work under this Agreement until Contractor shall have obtained all insurance required under this paragraph and such insurance shall have been approved by the District's Attorney as to form and carrier and the Harbormaster as to sufficiency, nor shall Contractor allow any contractor or subcontractor to commence work on this contract or subcontract until all similar insurance required of the Contractor and/or subcontractor shall have been so obtained and approved. All requirements herein provided shall appear either in the body of the insurance policies or as endorsements and shall specifically bind the insurance carrier.

Contractor shall procure and maintain for the duration of the contract all necessary insurance against claims for injuries to persons or damages to property which may arise from or in connection with the performance of the work hereunder by the Contractor, the Contractor's agents, representatives, employees or subcontractors.

**A. Minimum Scope of Insurance**

1. Coverage shall be at least as broad as:
  - a. Insurance Services Office Commercial General Liability coverage
  - b. Insurance Services Office form number covering Automobile Liability, code 1 (any auto)
  - c. Workers' Compensation insurance as required by the State of California and Employer's Liability Insurance
2. Certificates naming Noyo Harbor District as additional insured shall be provided by Contractor's insurance provider

**B. Minimum Limits of Insurance**

Contractor shall maintain limits no less than:

1. General Liability: \$2,000,000 per occurrence for bodily injury, personal injury and property damage (If Commercial General Liability Insurance or other form with a general aggregate liability is used, either the general aggregate limit shall apply separately to this project/location or the general aggregate limit shall be twice the required occurrence limit)
2. Automobile Liability: \$1,000,000 per accident for bodily injury and property damage
3. Employer's Liability: Bodily Injury by Accident, \$1,000,000 each accident; Bodily Injury by Disease, \$1,000,000; policy limit Bodily Injury by Disease, \$1,000,000 each employee
4. Bodily Injury or Death                                 \$1,000,000 each person  
   \$1,000,000 each occurrence
5. Property and Product Damage                     \$1,000,000 each occurrence  
   \$1,000,000 aggregate
6. Fire Insurance   90% of the full insurable value of all  
   insurable components of the Project



**C. Deductibles and Self-Insured Retentions**

Any deductibles or self-insured retentions must be declared to and approved by the District. At the option of the District, either: the insurer shall reduce or eliminate such deductibles or self-insured retentions as respects the District, its officers, officials, employees, and volunteers; the State of California, its officers, agents, employees and servants are hereby declared to be additional insured under the terms of this policy, as to activities of the Grantee and in respect to the Project, and this policy shall not be canceled without thirty (30) days prior written notice to Grantee; or the Contractor shall procure a bond guaranteeing payment of losses and related investigations, claim administration and defense expenses.

**D. Other Insurance Provisions**

The required general liability and automobile policies are to contain, or be endorsed to contain the following provisions:

1. The District, its officers, officials, employees, agents and volunteers, are to be covered as insured as respects: liability arising out of activities performed by or on behalf of the Contractor; products and completed operations of the Contractor; premises owned, occupied or used by the Contractor; or automobiles owned, leased, hired or borrowed by the Contractor. The coverage shall contain no special limitations on the scope of protection afforded to the District, its officers, officials, employees, agents or volunteers.
2. For any claims related to this project, the Contractor's insurance coverage shall be primary insurance as respects the District, its officers, officials, employees, agents, and volunteers. Any insurance or self-insurance maintained by the District, its officers, officials, employees, agents, or volunteers shall be excess of the Contractor's insurance and shall not contribute with it.
3. Any failure to comply with reporting or other provisions of the policies including breaches of warranties shall not affect coverage provided to the District, its officers, officials, employees, agents or volunteers.
4. The Contractor's insurance shall apply separately to each insured against whom claim is made or suit is brought except, with respect to the limits of the insurer's liability.
5. Each insurance policy required by this clause shall be endorsed to state that coverage shall not be suspended, voided, canceled by either party, reduced in coverage or in limits except after thirty (30) days' prior written notice by certified mail, return receipt requested, has been given to the District.

**E. Acceptability of Insurers**

Insurance is to be placed with insurers with a current A.M. Best's rating of no less than A:VII.

**F. Verification of Coverage**

Contractor shall furnish the District with original endorsements effecting coverage required by this clause. The endorsements are to be signed by a person authorized by that insurer to bind coverage on its behalf. The endorsements are to be on forms provided by the District. All endorsements are to be received and approved by the District before work commences. As an alternative to the District's forms, the Contractor's insurer may provide complete, certified copies of all required insurance policies, including endorsements affecting the coverage required by these specifications.

#### **Article 11: Indemnification**

- A. Contractor shall indemnify, defend with counsel acceptable to District, and hold harmless to the full extent permitted by law, the District, their officers, officials, employees, agents, and volunteers from and against any and all liability, loss, damage, claims, expenses, and costs (including, without limitation, attorney fees and costs and fees of litigation) (collectively, "Liability") of every nature arising out of or in connection with Contractor's performance of the Work or its failure to comply with any of its obligations contained in this Agreement, except such Liability caused by the active negligence, sole negligence or willful misconduct of the District. Such indemnification by the Contractor shall include, but not be limited to, liability of claims:
1. Resulting directly or indirectly from the performance of the Work by the Contractor, its subcontractors, suppliers, laborers, employees, or agents and any other person, firm, entity, or corporation furnishing or supplying work services, materials, or supplies in connection with the performance of this Agreement, and/or from any and all claims and losses accruing or resulting to any person, firm, entity, or corporation who may be injured or damaged by Contractor in performance of this agreement;
  2. Resulting directly or indirectly from the negligence or carelessness of the Contractor, its subcontractors, suppliers, laborers, employees, or agents in the performance of the Work, or in guarding or maintaining the same, or from any improper materials, implements, or appliances used in its construction, or by or on account of any act or omission of the Contractor, its employees, or agents;
  3. Arising directly or indirectly from bodily injury, occupational sickness or disease, or death of the Contractor's, or Supplier's own employees, or agents engaged in the Work resulting in actions brought by or on behalf of such employees against the District and/or the Construction Manager;
  4. Arising directly or indirectly from or based on the violation of any Laws or Regulations, whether by the Contractor, its subcontractors, employees, or agents;
  5. Arising directly or indirectly from the use or manufacture by the Contractor, its subcontractors, employees, or agents in the performance of this Agreement of any copyrighted or uncopyrighted composition, secret process, patented or unpatented invention, article, or appliance, unless otherwise specified stipulated in this Agreement;

6. Arising directly or indirectly from the breach of any warranties, whether express or implied, made to the District or any other parties by the Contractor, its subcontractors, employees, or agents;
  7. Arising directly or indirectly from the willful misconduct of the Contractor, its subcontractors, employees, or agents;
  8. Arising directly or indirectly from any breach of the obligations assumed in this Agreement by the Contractor;
  9. Arising directly or indirectly from, relating to, or resulting from a hazardous condition created by the Contractor, Subcontractors, Suppliers, or any of their employees or agents; and
  10. Arising directly, or indirectly, or consequentially out of any action, legal or equitable, brought against the District, Construction Manager, their consultants, sub consultants, and the officers, directors, employees and agents of each or any of them, to the extent caused by the Contractor's use of any premises acquired by permits, rights of way, or easements, the Site, or any land or area contiguous thereto or its performance of the Work thereon.
- B. The Contractor shall reimburse the District for all costs and expenses, (including but not limited to fees and charges of engineers, architects, attorneys, and other professionals and court costs of appeal) incurred by said District in enforcing the provisions of this Paragraph.
- C. The indemnification obligation under this Article 11 shall not be limited in any way by any limitation on the amount or type of insurance carried by Contractor or by the amount or type of damages, compensation, or benefits payable by or for the Contractor or any Subcontractor or other person or organization under workers' compensation acts, disability benefit acts, or other employee benefit acts.
- D. Pursuant to California Public Contract Code Section 9201, District shall timely notify Contractor of receipt of any third-party claim relating to this Agreement.

#### **Article 12: Disclaimer and Indemnity Concerning Labor Code Section 6400**

By executing this agreement the Contractor understands and agrees that with respect to the Work, and notwithstanding any provision in this contract to the contrary, the Contractor, and/or its privities, including, without limitation, subcontractors, suppliers and others engaged by the Contractor in the performance of the Work shall be "employers" for purposes of California Labor Code Section 6400 and related provisions of law, and that neither District nor its officials, officers, employees, agents, volunteers or consultants shall be "employers" pursuant to California Labor Code Section 6400 with respect to the performance of the Work by the Contractor and/or its privities.

The Contractor shall take all responsibility for the Work, shall bear all losses and damages directly or indirectly resulting to the Contractor, any subcontractors, the District, its officials, officers, employees, agents, volunteers and consultants, on account of the performance or character of the Work, unforeseen difficulties, accidents, or occurrences of other causes predicated on active or passive negligence of the Contractor or of any subcontractor, including, without limitation, all losses, damages or penalties directly or

indirectly resulting from exposure to hazards in performance of the Work in violation of the California Labor Code. The Contractor shall indemnify, defend and hold harmless the District, its officials, officers, employees, agents, volunteers and consultants from and against any or all losses, liability, expense, claim costs (including costs of defense), suits, damages and penalties (including, without limitation, penalties pursuant to the California Labor Code) directly or indirectly resulting from exposure to hazards in performance of the Work in violation of the California Labor Code, except such liability or costs caused by the active negligence, sole negligence or willful misconduct of the District.

### **Article 13: Independent Contractor**

It is understood and agreed that in the performance of this Agreement, Contractor (including its employees and agents) is acting in the capacity of an independent contractor, and not as an agent or employee of the District. Contractor has full control over the means and methods of performing said services and is solely responsible for its acts and omissions, including the acts and omissions of its employees and agents.

### **Article 14: Subcontractors**

Contractor must obtain the District's prior written consent for subcontracting any Work pursuant to this Agreement. Any such subcontractor shall comply, to the extent applicable, with the terms and conditions of this Agreement. Any agreement between Contractor and a subcontractor pursuant to this Agreement shall provide that the subcontractor procure and maintain insurance coverage as required herein and which shall name District as an additional insured.

### **Article 15: Compliance with Laws/Provisions**

#### **1. EQUAL EMPLOYMENT OPPORTUNITY**

During the performance of this contract, the contractor agrees as follows:

1.1 The contractor will not discriminate against any employee or applicant for employment because of race, color, religion, sex, sexual orientation, gender identity, or national origin. The contractor will take affirmative action to ensure that applicants are employed, and that employees are treated during employment without regard to their race, color, religion, sex, sexual orientation, gender identity, or national origin. Such action shall include, but not be limited to the following:

Employment, upgrading, demotion, or transfer; recruitment or recruitment advertising; layoff or termination; rates of pay or other forms of compensation; and selection for training, including apprenticeship. The contractor agrees to post in conspicuous places, available to employees and applicants for employment, notices to be provided setting forth the provisions of this nondiscrimination clause.

1.2 The contractor will, in all solicitations or advertisements for employees placed by or on behalf of the contractor, state that all qualified applicants will receive consideration for employment without regard to race, color, religion, sex, sexual orientation, gender identity, or national origin.

1.3 The contractor will not discharge or in any other manner discriminate against any employee or applicant for employment because such employee or applicant has inquired about, discussed, or disclosed the compensation of the employee or applicant or another employee or applicant. This provision shall not apply to instances in which an employee who has access to the compensation information of other employees or applicants as a part of such employee's essential job functions discloses the compensation of

such other employees or applicants to individuals who do not otherwise have access to such information, unless such disclosure is in response to a formal complaint or charge, in furtherance of an investigation, proceeding, hearing, or action, including an investigation conducted by the employer, or is consistent with the contractor's legal duty to furnish information.

1.4 The contractor will send to each labor union or representative of workers with which he has a collective bargaining agreement or other contract or understanding, a notice to be provided advising the said labor union or workers' representatives of the contractor's commitments under this section, and shall post copies of the notice in conspicuous places available to employees and applicants for employment.

1.5 The contractor will comply with all provisions of Executive Order 11246 of September 24, 1965, and of the rules, regulations, and relevant orders of the Secretary of Labor.

1.6 The contractor will furnish all information and reports required by Executive Order 11246 of September 24, 1965, and by rules, regulations, and orders of the Secretary of Labor, or pursuant thereto, and will permit access to his books, records, and accounts by the administering agency and the Secretary of Labor for purposes of investigation to ascertain compliance with such rules, regulations, and orders.

1.7 In the event of the contractor's noncompliance with the nondiscrimination clauses of this contract or with any of the said rules, regulations, or orders, this contract may be canceled, terminated, or suspended in whole or in part and the contractor may be declared ineligible for further Government contracts or federally assisted construction contracts in accordance with procedures authorized in Executive Order 11246 of September 24, 1965, and such other sanctions may be imposed and remedies invoked as provided in Executive Order 11246 of September 24, 1965, or by rule, regulation, or order of the Secretary of Labor, or as otherwise provided by law.

1.8 The contractor will include the portion of the sentence immediately preceding paragraph (1) and the provisions of paragraphs (1) through (8) in every subcontract or purchase order unless exempted by rules, regulations, or orders of the Secretary of Labor issued pursuant to section 204 of Executive Order 11246 of September 24, 1965, so that such provisions will be binding upon each subcontractor or vendor. The contractor will take such action with respect to any subcontract or purchase order as the administering agency may direct as a means of enforcing such provisions, including sanctions for noncompliance:

Provided, however, that in the event a contractor becomes involved in, or is threatened with, litigation with a subcontractor or vendor as a result of such direction by the administering agency, the contractor may request the United States to enter into such litigation to protect the interests of the United States.

The applicant further agrees that it will be bound by the above equal opportunity clause with respect to its own employment practices when it participates in federally assisted construction work: Provided, that if the applicant so participating is a State or local government, the above equal opportunity clause is not applicable to any agency, instrumentality or subdivision of such government which does not participate in work on or under the contract.

The applicant agrees that it will assist and cooperate actively with the administering agency and the Secretary of Labor in obtaining the compliance of contractors and subcontractors with the equal opportunity clause and the rules, regulations, and relevant orders of the Secretary of Labor, that it will furnish the administering agency and the Secretary of Labor such information as they may require for the supervision of such compliance, and that it will otherwise assist the administering agency in the discharge of the agency's primary responsibility for securing compliance.

The applicant further agrees that it will refrain from entering into any contract or contract modification subject to Executive Order 11246 of September 24, 1965, with a contractor debarred from, or who has not demonstrated eligibility for, Government contracts and federally assisted construction contracts pursuant to the Executive Order and will carry out such sanctions and penalties for violation of the equal opportunity clause as may be imposed upon contractors and subcontractors by the administering agency or the Secretary of Labor pursuant to Part II, Subpart D of the Executive Order. In addition, the applicant agrees that if it fails or refuses to comply with these undertakings, the administering agency may take any or all of the following actions: Cancel, terminate, or suspend in whole or in part this grant (contract, loan, insurance, guarantee); refrain from extending any further assistance to the applicant under the program with respect to which the failure or refund occurred until satisfactory assurance of future compliance has been received from such applicant; and refer the case to the Department of Justice for appropriate legal proceedings.

## 2. CONTRACT WORK HOURS AND SAFETY STANDARDS ACT

2.1 *Overtime requirements.* No contractor or subcontractor contracting for any part of the contract work which may require or involve the employment of laborers or mechanics shall require or permit any such laborer or mechanic in any workweek in which he or she is employed on such work to work in excess of forty hours in such workweek unless such laborer or mechanic receives compensation at a rate not less than one and one-half times the basic rate of pay for all hours worked in excess of forty hours in such workweek.

2.2 *Violation; liability for unpaid wages; liquidated damages.* In the event of any violation of the clause set forth in paragraph (b)(1) of this section the contractor and any subcontractor responsible therefor shall be liable for the unpaid wages. In addition, such contractor and subcontractor shall be liable to the United States (in the case of work done under contract for the District of Columbia or a territory, to such District or to such territory), for liquidated damages. Such liquidated damages shall be computed with respect to each individual laborer or mechanic, including watchmen and guards, employed in violation of the clause set forth in paragraph (b)(1) of this section, in the sum of \$27 for each calendar day on which such individual was required or permitted to work in excess of the standard workweek of forty hours without payment of the overtime wages required by the clause set forth in paragraph (b)(1) of this section.

2.3 *Withholding for unpaid wages and liquidated damages.* The Noyo Harbor District shall upon its own action or upon written request of an authorized representative of the Department of Labor withhold or cause to be withheld, from any moneys payable on account of work performed by the contractor or subcontractor under any such contract or any other Federal contract with the same prime contractor, or any other federally-assisted contract subject to the Contract Work Hours and Safety Standards Act, which is held by the same prime contractor, such sums as may be determined to be necessary to satisfy any liabilities of such contractor or subcontractor for unpaid wages and liquidated damages as provided in the clause set forth in paragraph (b)(2) of this section.

2.4 *Subcontracts.* The contractor or subcontractor shall insert in any subcontracts the clauses set forth in paragraph (b)(1) through (4) of this section and also a clause requiring the subcontractors to include these clauses in any lower tier subcontracts. The prime contractor shall be responsible for compliance by any subcontractor or lower tier subcontractor with the clauses set forth in paragraphs 2.1 through 2.4 of this section.

## 3. CLEAN AIR ACT

3.1 The contractor agrees to comply with all applicable standards, orders or regulations issued pursuant to the Clean Air Act, as amended, 42 U.S.C. § 7401 et seq.

3.2 The contractor agrees to report each violation to the Noyo Harbor District and understands and agrees that the Noyo Harbor District will, in turn, report each violation as required to assure notification to the ARPA Administrator, and the appropriate Environmental Protection Agency Regional Office.

3.3 The contractor agrees to include these requirements in each subcontract exceeding \$150,000 financed in whole or in part with Federal assistance provided by ARPA.

#### 4. FEDERAL WATER POLLUTION CONTROL ACT

4.1 The contractor agrees to comply with all applicable standards, orders, or regulations issued pursuant to the Federal Water Pollution Control Act, as amended, 33 U.S.C. 1251 et seq.

4.2 The contractor agrees to report each violation to the Noyo Harbor District and understands and agrees that the Noyo Harbor District will, in turn, report each violation as required to assure notification to the ARPA Administrator, and the appropriate Environmental Protection Agency Regional Office.

The contractor agrees to include these requirements in each subcontract exceeding \$150,000 financed in whole or in part with Federal assistance provided by ARPA.

#### 5. DEBARMENT AND SUSPENSION

5.1 This contract is a covered transaction for purposes of 2 C.F.R. pt. 180 and 2 C.F.R. pt. 3000. As such, the contractor is required to verify that none of the contractor's principals (defined at 2 C.F.R. § 180.995) or its affiliates (defined at 2 C.F.R. § 180.905) are excluded (defined at 2 C.F.R. § 180.940) or disqualified (defined at 2 C.F.R. § 180.935).

5.2 The contractor must comply with 2 C.F.R. pt. 180, subpart C and 2 C.F.R. pt. 3000, subpart C, and must include a requirement to comply with these regulations in any lower tier covered transaction it enters into.

5.3 This certification is a material representation of fact relied upon by Noyo Harbor District. If it is later determined that the contractor did not comply with 2 C.F.R. pt. 180, subpart C and 2 C.F.R. pt. 3000, subpart C, in addition to remedies available to Noyo Harbor District, the Federal Government may pursue available remedies, including but not limited to suspension and/or debarment.

5.4 The bidder or proposer agrees to comply with the requirements of 2 C.F.R. pt. 180, subpart C and 2 C.F.R. pt. 3000, subpart C while this offer is valid and throughout the period of any contract that may arise from this offer. The bidder or proposer further agrees to include a provision requiring such compliance in its lower tier covered transactions.

#### 6. BYRD ANTI-LOBBYING AMENDMENT, 31 U.S.C. § 1352 (AS AMENDED)

Contractors who apply or bid for an award of \$100,000 or more shall file the required certification. Each tier certifies to the tier above that it will not and has not used Federal appropriated funds to pay any person or organization for influencing or attempting to influence an officer or employee of any agency, a Member of Congress, officer or employee of Congress, or an employee of a Member of Congress in connection with

obtaining any Federal contract, grant, or any other award covered by 31 U.S.C. § 1352. Each tier shall also disclose any lobbying with non-Federal funds that takes place in connection with obtaining any Federal award. Such disclosures are forwarded from tier to tier up to the recipient who in turn will forward the certification(s) to the awarding agency.

If applicable, contractors must sign and submit to the non-federal entity the following certification.

APPENDIX A, 44 C.F.R. PART 18 – CERTIFICATION REGARDING LOBBYING

Certification for Contracts, Grants, Loans, and Cooperative Agreements

The undersigned certifies, to the best of his or her knowledge and belief, that:

6.1 No Federal appropriated funds have been paid or will be paid, by or on behalf of the undersigned, to any person for influencing or attempting to influence an officer or employee of an agency, a Member of Congress, an officer or employee of Congress, or an employee of a Member of Congress in connection with the awarding of any Federal contract, the making of any Federal grant, the making of any Federal loan, the entering into of any cooperative agreement, and the extension, continuation, renewal, amendment, or modification of any Federal contract, grant, loan, or cooperative agreement.

6.2 If any funds other than Federal appropriated funds have been paid or will be paid to any person for influencing or attempting to influence an officer or employee of any agency, a Member of Congress, an officer or employee of Congress, or an employee of a Member of Congress in connection with this Federal contract, grant, loan, or cooperative agreement, the undersigned shall complete and submit Standard Form-LLL, "Disclosure Form to Report Lobbying," in accordance with its instructions.

6.3 The undersigned shall require that the language of this certification be included in the award documents for all subawards at all tiers (including subcontracts, subgrants, and contracts under grants, loans, and cooperative agreements) and that all subrecipients shall certify and disclose accordingly.

This certification is a material representation of fact upon which reliance was placed when this transaction was made or entered into. Submission of this certification is a prerequisite for making or entering into this transaction imposed by section 1352, title 31, U.S. Code. Any person who fails to file the required certification shall be subject to a civil penalty of not less than \$10,000 and not more than \$100,000 for each such failure.

The Contractor, \_\_\_\_\_, certifies or affirms the truthfulness and accuracy of each statement of its certification and disclosure, if any. In addition, the Contractor understands and agrees that the provisions of 31 U.S.C. Chap. 38, Administrative Remedies for False Claims and Statements, apply to this certification and disclosure, if any.

\_\_\_\_\_  
Signature of Contractor's Authorized Official

\_\_\_\_\_  
Name and Title of Contractor's Authorized Official

\_\_\_\_\_  
Date



## 7. PROCUREMENT OF RECOVERED MATERIALS

7.1 In the performance of this contract, the Contractor shall make maximum use of products containing recovered materials that are EPA-designated items unless the product cannot be acquired—

7.1.1 Competitively within a timeframe providing for compliance with the contract performance schedule;

7.1.2 Meeting contract performance requirements; or

7.1.3 At a reasonable price.

7.2 Information about this requirement, along with the list of EPA- designated items, is available at EPA's Comprehensive Procurement Guidelines web site, <https://www.epa.gov/smm/comprehensive-procurement-guideline-cpg-program>.

7.3 The Contractor also agrees to comply with all other applicable requirements of Section 6002 of the Solid Waste Disposal Act.”

## 8. ACCESS TO RECORDS

The following access to records requirements apply to this contract:

8.1 The Contractor agrees to provide Noyo Harbor District, ARPA Grant representatives, the Comptroller General of the United States, or any of their authorized representatives access to any books, documents, papers, and records of the Contractor which are directly pertinent to this contract for the purposes of making audits, examinations, excerpts, and transcriptions.

8.2 The Contractor agrees to permit any of the foregoing parties to reproduce by any means whatsoever or to copy excerpts and transcriptions as reasonably needed.

8.3 The Contractor agrees to provide the ARPA Grant Administrators or its authorized representatives access to construction or other work sites pertaining to the work being completed under the contract.

### **Article 16: Notices**

All notices required or permitted by this Agreement, including notice of change of address, shall be in writing and given by personal delivery or sent postage prepaid and addressed to the parties intended to be notified, as set forth herein. Notice shall be deemed given as of the date of delivery in person or as of the date deposited in any post office or post office box regularly maintained by the United States Postal Service, unless otherwise stated herein.

Notice shall be given as follows:

District: Harbormaster  
Noyo Harbor District  
19101 S. Harbor Drive  
Fort Bragg, CA 95437  
Telephone: (707) 964-4719

Contractor: Principal  
Company  
Street  
City, State  
Phone Number

**Article 17: Governing Law/Venue**

This Agreement shall be construed and its performance enforced under California law. Venue shall be in the Superior Court of the State of California in the County of Mendocino.

**Article 18: Non-Waiver**

The District's failure to enforce any provision of this Agreement or the waiver of any provision in a particular instance shall not be construed as a general waiver of any part of such provision. The provision shall remain in full force and effect.

**Article 19: Third Party Beneficiaries**

The Parties do not intend, by any provision of this Agreement, to create in any third party any benefit or right owed by one party, under the terms and conditions of this Agreement, to the other party.

## **Article 20: Assignment**

No assignment by a party hereto of any rights under or interests in the Contract Documents will be binding on another party hereto without the written consent of the party sought to be bound; and specifically but without limitation monies that may become due and monies that are due may not be assigned without such consent (except to the extent that the effect of this restriction may be limited by law), and unless specifically stated to the contrary in any written consent to an assignment, no assignment will release or discharge the assignor from any duty or responsibility under the Contract Documents.

District and Contractor each binds itself, its partners, successors, assigns and legal representatives to the other party hereto, its partners, successors, assigns and legal representatives in respect of all covenants, agreements and obligations contained in the Contract Documents.

## **Article 21: Severability**

If any term or portion of this Agreement is held to be invalid, illegal, or otherwise enforceable by a court of competent jurisdiction, the remaining provisions of this Agreement shall continue in full force and effect.

## **Article 22: Attorney's Fees**

If any legal action or proceeding arising out of or relating to this Agreement is brought by either party to this Agreement, the prevailing party shall be entitled to receive from the other party, in addition to any other relief that may be granted, the reasonable attorneys' fees, costs, and expenses incurred in the action or proceeding by the prevailing party.

## **Article 23: Sole and Only Agreement**

This Agreement constitutes the sole and only Agreement between the parties. Any agreements or representations not expressly set forth in this instrument are null and void.

Signatures Appear On Next Page

In Witness Whereof, District and Contractor have caused this Agreement to be executed the day and year first above written.

District

Contractor

By \_\_\_\_\_

(Corporate Seal)

Attest \_\_\_\_\_

Attest \_\_\_\_\_

Address for giving notices  
Noyo Harbor District  
19101 S. Harbor Drive  
Fort Bragg, CA. 95437

Address for giving notices  
\_\_\_\_\_  
\_\_\_\_\_

License No. \_\_\_\_\_

Approved as to Form:

\_\_\_\_\_  
(Signature)

Agent for service of process:  
\_\_\_\_\_  
(Title)

End of Agreement

**This Page Left Intentionally Blank.**

# Agreement Certificate

STATE OF CALIFORNIA (if Corporation)

\_\_\_\_\_ ) ss:

COUNTY OF \_\_\_\_\_ )

I HEREBY CERTIFY that a meeting of the Board of Directors of the \_\_\_\_\_ a corporation existing under the laws of the State of \_\_\_\_\_, held on \_\_\_\_\_, 20\_\_\_\_, the following resolution was duly passed and adopted:

"RESOLVED, that \_\_\_\_\_, as \_\_\_\_\_ President of the Corporation, be and is hereby authorized to execute the Agreement dated \_\_\_\_\_, 20\_\_\_\_, by and between this Corporation and \_\_\_\_\_ and that his/her execution thereof, attested by the Secretary of the Corporation, and with the Corporate Seal affixed, shall be the official act and deed of this Corporation."

I further certify that said resolution is now in full force and effect.

IN WITNESS WHEREOF, I have hereunto set my hand and affixed the official seal of the corporation this \_\_\_\_\_, day of \_\_\_\_\_, 20\_\_\_\_\_.

\_\_\_\_\_  
Secretary

(SEAL)

**This Page Left Intentionally Blank.**

# Agreement Certificate

STATE OF CALIFORNIA (if Partnership)

\_\_\_\_\_ ) ss:

COUNTY OF \_\_\_\_\_ )

I HEREBY CERTIFY that a meeting of the Partners of the

\_\_\_\_\_ a partnership

existing under the laws of the State of \_\_\_\_\_, held on \_\_\_\_\_,

20\_\_\_\_, the following resolution was duly passed and adopted:

"RESOLVED, that \_\_\_\_\_, as the General Partner of the Partnership, be and is hereby authorized to execute the Agreement dated \_\_\_\_\_, 20\_\_\_\_ by and between this Partnership and \_\_\_\_\_, and that his/her execution thereof, attested by the \_\_\_\_\_ shall be the official act and deed of this Partnership."

I further certify that said resolution is now in full force and effect.

IN WITNESS WHEREOF, I have hereunto set my hand this \_\_\_\_\_ day of \_\_\_\_\_, 20\_\_\_\_.

\_\_\_\_\_  
Partner

(SEAL)



**This Page Left Intentionally Blank.**

# Agreement Certificate

(if Joint Venture)

STATE OF CALIFORNIA

\_\_\_\_\_ ) ss:  
COUNTY OF \_\_\_\_\_ )

I HEREBY CERTIFY that a meeting of the Principals of the

\_\_\_\_\_ a

joint venture existing under the laws of the State of \_\_\_\_\_, held  
on \_\_\_\_\_, 20\_\_\_\_, the following resolution was duly passed and adopted:

"RESOLVED, that \_\_\_\_\_, as  
\_\_\_\_\_, of the joint venture, be and is hereby authorized to execute the  
Agreement dated \_\_\_\_\_, 20\_\_\_\_, by and between this Joint Venture and  
\_\_\_\_\_ and that his/her execution thereof,  
attested by the \_\_\_\_\_ shall be the official act and deed of this Joint  
Venture."

I further certify that said resolution is now in full force and effect.

IN WITNESS WHEREOF, I have hereunto set my hand this \_\_\_\_\_, day of  
\_\_\_\_\_, 20\_\_\_\_\_.

\_\_\_\_\_  
Managing Partner

(SEAL)

**This Page Left Intentionally Blank.**

# NOYO HARBOR DISTRICT GRADER PARK FISH CLEANING STATION

19101 SOUTH HARBOR DR.  
FORT BRAGG, CALIFORNIA



PREPARED BY:



MAY 2024

### INDEX OF SHEETS

SEQ	SHT	TITLE
1	G1.0	COVER
2	G2.0	STANDARD ABBREVIATIONS AND LEGENDS
3	G3.0	NOTES AND SPECIFICATIONS
4	C1.0	SITE PLAN
5	C2.0	GRADING PLAN
6	C3.0	DETAILS
7	C3.1	DETAILS
8	A1.0	FLOOR PLAN AND ELEVATIONS
9	A2.0	ARCHITECTURAL DETAILS
10	S1.0	FASTENING SCHEDULE

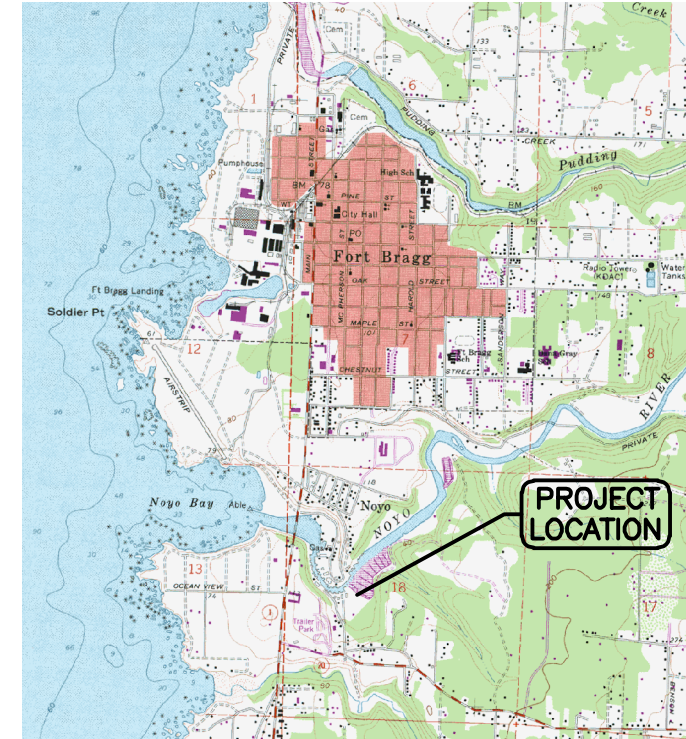

SAVED: 5/2/2024 9:41 AM CNEWELL, PLOTTED: 5/2/2024 9:42 AM NEWELL, CHRIS  
 P:\Willits\2021\421058-Noyo-CSP\101-Fish-Cleaning\Draws\421058-101-COVER.dwg



VERIFY SCALES  
 BAR IS ONE INCH ON ORIGINAL DRAWING  
 0 1"  
 IF NOT ONE INCH ON SCALES ACCORDINGLY

535 S. MAIN ST.  
 SUITE 200  
 WILKESBORO, NC 28696  
 WWW.SN-CORP.COM  
 707-459-4516



NO.	DATE	REVISION	BY

NOYO HARBOR DISTRICT  
 GRADER PARK FISH CLEANING STATION  
 19101 SOUTH HARBOR DR., FORT BRAGG, CALIFORNIA

**COVER**

SHEET  
**G1.0**

SEQ  
 DATE **05/2024**  
 PROJ. NO.  
**421058.101**

5/2/2024

**ABBREVIATIONS**

Table of abbreviations for letters A through Q, listing various engineering and construction terms such as ABANDON, ANCHOR BOLT, ASPHALTIC CONCRETE, etc.

**CURVE DATA**

- R (RADIUS)
- L (LENGTH)
- Δ (DELTA)
- T (TANGENT)

**UTILITIES LEGEND**

Utilities Legend table showing symbols for PROPOSED and EXISTING utilities like GATE VALVE, PLUG VALVE, BALL VALVE, BUTTERFLY VALVE, etc.

**NOTES**

- 1. CONTACT THE ENGINEER FOR SYMBOLS NOT LISTED.
- 2. THIS IS A STANDARD SHEET, THEREFORE, SOME SYMBOLS OR ABBREVIATIONS MAY APPEAR ON THIS SHEET WHICH DO NOT APPEAR ON THE PLANS.
- 3. SITE AND UTILITY SYMBOLS SHOWN ON THIS SHEET ARE NOT INTENDED TO REPRESENT THE PHYSICAL SCALE OR SHAPE OF ANY ITEMS. WHERE LARGE-SCALE PLANS ARE PRESENTED, THE SYMBOLS SHOWN HEREON MAY BE REPLACED BY DETAILS MORE SUITED TO THE DRAWING SCALE.

**TOPOGRAPHIC LEGEND**

Topographic Legend table showing symbols for PROPOSED and EXISTING features like P.I. (POINT OF INTERSECTION), TEMPORARY BENCH MARK, FINISH GRADE ELEVATION, etc.

**DETAIL AND SECTION DESIGNATION**

SECTION (LETTER) OR DETAIL (NUMERAL) DESIGNATION

INDICATES SECTION OR DETAIL TAKEN AND SHOWN ON SAME SHEET

ON DRAWING WHERE SECTION OR DETAIL IS TAKEN:

SHEET NUMBER WHERE SHOWN

ON DRAWING WHERE SECTION OR DETAIL IS SHOWN:

SHEET NUMBER WHERE TAKEN

STANDARD DETAIL NUMBER (DETAIL MAY BE SHOWN ON ANY SHEET WITHIN THE DRAWING SET)

VERIFY SCALES  
BAR IS ONE INCH ON ORIGINAL DRAWING  
IF NOT ONE INCH ON SCALES ACCORDINGLY

535 S. MAIN ST  
SUNNYVALE, CA 94086  
WWW.SQW.COM  
707-459-4518



BY

REVISION

DATE

NO.

APVD

NOYO HARBOR DISTRICT  
GRADER PARK FISH CLEANING STATION  
19101 SOUTH HARBOR DR., FORT BRAGG, CALIFORNIA  
**STANDARD ABBREVIATIONS AND LEGENDS**

SHEET **G2.0**  
SEQ  
DATE **05/2024**  
PROJ. NO. **421058.101**  
5/2/2024





## GENERAL NOTES:

- ALL WORK SHALL CONFORM TO CURRENT CALIFORNIA BUILDING CODE.
- THE WORKING DRAWINGS ARE GENERALLY DIAGRAMMATIC. THEY DO NOT SHOW EVERY OFFSET, BEND OR ELBOW REQUIRED FOR INSTALLATION IN THE SPACE PROVIDED. THEY DO NOT SHOW EVERY DIMENSION, COMPONENT PIECE, SECTION, JOINT OR FITTING REQUIRED TO COMPLETE THE PROJECT. ALL LOCATIONS FOR WORK SHALL BE CHECKED AND COORDINATED WITH EXISTING CONDITIONS IN THE FIELD BEFORE BEGINNING CONSTRUCTION. EXISTING UNDERGROUND UTILITIES WITHIN THE LIMITS OF EXCAVATION SHALL BE VERIFIED AS TO LOCATION, SIZE AND LOCATION BY UNCOVERING, PROVIDED SUCH IS PERMITTED BY LOCAL PUBLIC AUTHORITIES WITH JURISDICTION, BEFORE BEGINNING CONSTRUCTION. CONTRACTOR SHALL NOTIFY ENGINEER OF ANY DISCREPANCIES.
- THE CONTRACTOR SHALL SECURE ALL NECESSARY PERMITS PRIOR TO THE COMMENCEMENT OF CONSTRUCTION.
- THE CONTRACTOR SHALL PROVIDE A COPY OF THE TRENCH PERMIT FROM THE CALIFORNIA DIVISION OF INDUSTRIAL SAFETY PRIOR TO THE EXCAVATION OF ANY TRENCH OVER FIVE FEET IN DEPTH.
- CONTRACTOR SHALL PERFORM TRENCH WORK IN CONFORMANCE WITH THE CALIFORNIA DIVISION OF INDUSTRIAL SAFETY REQUIREMENTS AND SHALL CONFORM TO ALL APPLICABLE OCCUPATIONAL SAFETY AND HEALTH STANDARDS, RULES, REGULATIONS AND ORDERS ESTABLISHED BY THE STATE OF CALIFORNIA AND OTHER APPLICABLE AGENCIES.
- CONTRACTOR AGREES THAT IN ACCORDANCE WITH GENERALLY ACCEPTED CONSTRUCTION PRACTICES, GENERAL CONTRACTOR WILL ASSUME SOLE AND COMPLETE RESPONSIBILITY FOR JOB SITE CONDITIONS DURING THE COURSE OF CONSTRUCTION OF THE PROJECT, INCLUDING SAFETY OF ALL PERSONS AND PROPERTY. ALL WORK AND EQUIPMENT SHALL COMPLY WITH THE CALIFORNIA DIVISION OF INDUSTRIAL SAFETY REQUIREMENTS. THIS REQUIREMENT SHALL BE MADE TO APPLY CONTINUOUSLY, AND NOT BE LIMITED TO NORMAL WORKING HOURS. CONTRACTOR FURTHER AGREES TO HOLD HARMLESS, INDEMNIFY AND DEFEND THE OWNER, THE ENGINEER AND HIS/HER CONSULTANTS.
- THE CONTRACTOR SHALL INDEPENDENTLY REVIEW GROUND TOPOGRAPHY AND TREE CONDITIONS THROUGHOUT THE SITE, AND ASSUME THE RISK OF COMPLETING THE WORK SET OUT ON THESE PLANS, REGARDLESS OF ROCK, WATER TABLE OR OTHER CONDITIONS WHICH MAY BE ENCOUNTERED IN THE COURSE OF THE WORK.
- ANY DISCREPANCY DISCOVERED BY THE CONTRACTOR IN THESE PLANS, OR ANY FIELD CONDITIONS DISCOVERED BY THE CONTRACTOR THAT MAY DELAY OR OBSTRUCT THE PROPER COMPLETION OF THE WORK SHOWN HEREIN SHALL BE BROUGHT TO THE ATTENTION OF THE OWNER AND THE ENGINEER IMMEDIATELY UPON DISCOVERY. SAID NOTIFICATION SHALL BE IN WRITING.
- ALL UNDERGROUND IMPROVEMENTS SHALL BE INSTALLED TESTED AND APPROVED PRIOR TO PAVING.
- THE CONTRACTOR SHALL NOT BEGIN EXCAVATING UNTIL ALL EXISTING UTILITIES HAVE BEEN MARKED IN THE FIELD. THE CONTRACTOR SHALL NOTIFY EACH APPLICABLE ENTITY AT LEAST 48 HOURS PRIOR TO COMMENCING WORK. CALL UNDERGROUND SERVICE ALERT (USA) TWO WORKING DAYS BEFORE DIGGING AT (800) 227-2600 FOR LOCATES.
- GRADING AND CONSTRUCTION CONTRACTORS SHALL STOP WORK AND NOTIFY THE OWNER AND THE ENGINEER IF CULTURAL RESOURCES ARE DISCOVERED DURING CONSTRUCTION.
- THE CONTRACTOR SHALL GIVE THE INSPECTOR 48 HOURS ADVANCE NOTICE OF ANY CONSTRUCTION OR REQUIRED TESTING.
- SHOULD THE CONTRACTOR OR ANY OF HIS AGENTS OR EMPLOYEES ENCOUNTER OR DISCOVER MATERIALS WHICH APPEAR TO BE HAZARDOUS DURING THE PERFORMANCE OF THE WORK, THE CONTRACTOR SHALL INFORM THE ENGINEER IMMEDIATELY AND SUSPEND WORK IN THE AFFECTED AREA UNTIL THE ENGINEER HAS INSPECTED THE LOCATION AND MATERIALS IN QUESTION. SHOULD IT BE NECESSARY TO UNDERTAKE REMEDIATION, THE ENGINEER WILL GIVE WRITTEN NOTICE TO SUSPEND WORK IN THE AFFECTED AREA UNTIL THE PROPER COURSE OF ACTION HAS BEEN DETERMINED. OPERATIONS IN THE AFFECTED AREA SHALL BE RESUMED ONLY UPON WRITTEN NOTICE BY THE ENGINEER.
- ALL SITE GRADING WILL BE INSPECTED BY THE ENGINEER. COMPACTION TESTING WILL BE CONDUCTED AFTER SUFFICIENT DENSITIES HAVE BEEN ACHIEVED IN THE CONTRACTOR'S OPINION. THE CONTRACTOR SHALL MAKE ALL REQUESTS FOR MATERIALS TESTING AT LEAST 48 HOURS IN ADVANCE. ANY SOILS THAT FAIL TO MEET THE REQUIRED COMPACTION LEVELS SHALL BE REMOVED, AND RECOMPACTED. ALL COSTS ASSOCIATED WITH ACHIEVING COMPACTION STANDARDS SHALL BE INCLUDED IN THE CONTRACTOR'S ORIGINAL BID.
- TOPSOIL SHALL BE REMOVED FROM CUT AND FILL AREAS AND SHALL NOT BE USED FOR ENGINEERED FILL. TOPSOIL SHALL BE STOCKPILED SEPARATELY AND REPLACED OVER AREAS OF EXPOSED SUBGRADE TO A MINIMUM DEPTH OF 6 INCHES.
- NO CHANGES OR MODIFICATIONS SHALL BE MADE TO THESE PLANS WITHOUT WRITTEN APPROVAL BY THE ENGINEER.

## SURVEY NOTES:

HORIZONTAL DATUM: CCS83 ZONE 2, U.S. SURVEY FEET, BASED UPON GPS OBSERVATIONS, PROCESSED BY NGS OPUS (APRIL 18, 2022) WITH CORS STATIONS P319, P059, P165, P164, P190, P157, P329, P188, P158 REFERENCE EPOCH 2010.00 AT CONTROL POINT #101

VERTICAL DATUM: NAVD 88, U.S. SURVEY FEET, BASED UPON GPS OBSERVATIONS, PROCESSED BY NGS OPUS (APRIL 18, 2022) WITH CORS STATIONS P319, P059, P165, P164, P190, P157, P329, P188, P158 REFERENCE EPOCH 2010.00 AT CONTROL POINT #101

UNDERGROUND UTILITY NOTE:  
UNDERGROUND UTILITY INFORMATION SHOWN IS BASED ON VISIBLE EVIDENCE. SHN MAKES NO GUARANTEE REGARDING LOCATION, TYPE, SIZE, NOR PRESENCE OR ABSENCE OF UNDERGROUND UTILITIES. IRRIGATION SYSTEM NOT MAPPED.

OVERHEAD UTILITY NOTE:  
OVERHEAD LINES OFF OF THE PROJECT SITE ARE NOT FULLY MAPPED. INFORMATION SHOWN IS BASED ON VISIBLE EVIDENCE. NO MAPPING OBTAINED FOR PHONE AND CABLE TELEVISION FACILITIES. PHONE AND CABLE TELEVISION LINE LOCATIONS NOT VERIFIED.

TREE NOTE:  
ALL TREES SURVEYED WERE DECIDUOUS UNLESS NOTED OTHERWISE. INDIVIDUAL TRUNKS IN TREE CLUSTERS NOT SHOWN.

## CONSTRUCTION NOTES

- VERIFICATION: VERIFY ALL DIMENSIONS, ELEVATIONS, AND SITE CONDITIONS BEFORE STARTING WORK. NOTIFY THE EOR IMMEDIATELY OF ANY DISCREPANCIES.
- CODES: ALL MATERIALS AND WORK SHALL CONFORM TO THE REQUIREMENTS OF THE STATE OF CALIFORNIA BUILDING CODE.
- SUBSTITUTIONS: PROVIDE MANUFACTURER'S APPROVED PRODUCT EVALUATION REPORTS AND A LIST OF ALL PROPOSED SUBSTITUTIONS TO THE EOR FOR PREVIEW AND APPROVAL BEFORE FABRICATION AND/OR INSTALLATION.
- SIMILAR WORK: WHERE CONSTRUCTION DETAILS ARE NOT SHOWN OR NOTED FOR ANY PART OF THE WORK, SUCH DETAILS SHALL BE THE SAME AS FOR SIMILAR WORK SHOWN ON THE DRAWINGS.
- PIPES, DUCTS, SLEEVES, CHASES, ETC.: SHALL NOT BE PLACED IN SLABS, BEAMS, OR WALLS UNLESS SPECIFICALLY SHOWN OR NOTED, NOR SHALL ANY STRUCTURAL MEMBER BE CUT FOR PIPES, DUCTS, ETC., UNLESS SPECIFICALLY SHOWN. OBTAIN PRIOR APPROVAL FOR INSTALLATION OF ANY ADDITIONAL PIPES, DUCTS, ETC.
- CONSTRUCTION LOADS: MATERIALS SHALL BE EVENLY DISTRIBUTED IF PLACED ON FRAMED FLOORS OR ROOFS. LOADS SHALL NOT EXCEED THE ALLOWABLE LOADING FOR THE SUPPORTING MEMBERS AND THEIR CONNECTIONS.
- CONSTRUCTION METHODS AND PROJECT SAFETY: THE CONTRACT DRAWINGS AND SPECIFICATIONS REPRESENT THE FINISHED STRUCTURE AND DO NOT INDICATE METHODS, PROCEDURES OR SEQUENCE OF CONSTRUCTION. TAKE NECESSARY PRECAUTIONS TO MAINTAIN AND ENSURE THE INTEGRITY OF THE STRUCTURE DURING CONSTRUCTION, NEITHER THE OWNER NOR THE DESIGNER/ENGINEER WILL ENFORCE SAFETY MEASURES OR REGULATIONS. CONTRACTOR SHALL DESIGN, CONSTRUCT AND MAINTAIN ALL SAFETY DEVICES, INCLUDING SHORING AND BRACING, AND SHALL BE SOLELY RESPONSIBLE FOR CONFORMING TO ALL LOCAL, STATE AND FEDERAL SAFETY AND HEALTH STANDARDS, LAWS AND REGULATIONS.

## GEOTECHNICAL NOTES:

GROUNDWATER:  
GROUNDWATER WAS NOT ENCOUNTERED DURING THE LIMITED SOILS INVESTIGATION PERFORMED AT THE SITE ON 4/12/22. THE INVESTIGATION INCLUDED LOGGING SOILS TO A FULL DEPTH OF 2 FEET BELOW THE GROUND SURFACE

SITE PREPARATION AND GRADING:  
REMOVE DEBRIS, ORGANICS, LOOSE SOIL, TREES, ROOTS, AND ANY OTHER UNSUITABLE MATERIAL FOR A DISTANCE OF AT LEAST 5 FEET BEYOND THE LIMITS OF IMPROVEMENTS. STRIPPING TO A DEPTH OF ABOUT 2 TO 4 INCHES MAY BE NEEDED TO REMOVE SURFACE SOILS CONTAINING GRASS AND ROOTS. ANY VEGETATION AND ORGANIC TOPSOIL WITH MORE THAN 2 PERCENT ORGANIC MATERIAL BY DRY WEIGHT SHOULD BE REMOVED FROM THE SITE OR STOCKPILED FOR REUSE IN LANDSCAPE AREAS. THE ENGINEER SHOULD OBSERVE AND APPROVE THE PREPARED SITE PRIOR TO ANY EXCAVATION, SUBGRADE PREPARATION, AND PLACEMENT OF FILL OR IMPROVEMENTS.

SURFACE DRAINAGE:  
SURFACE DRAINAGE SHOULD BE PLANNED TO PREVENT PONDING AND ENABLE WATER TO DRAIN AWAY FROM FOUNDATIONS AND SLABS-ON-GRADE, AND TOWARDS SUITABLE COLLECTION OR DISCHARGE FACILITIES.

THE CONTRACTOR SHALL BE RESPONSIBLE FOR THE STABILITY OF ALL TEMPORARY EXCAVATIONS AND SHOULD COMPLY WITH APPLICABLE OCCUPATIONAL SAFETY AND HEALTH ADMINISTRATION (OSHA) REGULATIONS (CALIFORNIA CONSTRUCTION SAFETY ORDERS, TITLE B).

## EROSION CONTROL NOTES:

- BMPs SHALL BE INSTALLED PRIOR TO ANY SITE DISTURBANCE AND MAINTAINED SUCH THAT NO VISIBLE SEDIMENT LEAVES THE SITE.
- TRACKING CONTROLS: ENTRANCE/EXIT BMP.
- PAVED AREAS AT THE ACCESS POINTS SHALL BE SWEEPED OR VACUUMED AS OFTEN AS EACH DAY TO ELIMINATE TRACKING SOIL AND DEBRIS BEYOND THE LIMITS OF THE PROJECT SITE. ANY SOILS AND/OR DEBRIS, ROCK, GRAVEL, ETC. TRACKED BEYOND THE LIMITS OF THE PROJECT SITE AS A RESULT OF THIS PROJECT SHALL BE REMOVED IMMEDIATELY.
- DISTURBED AREAS SHALL BE PROTECTED TO EXTENT PRACTICAL DURING CONSTRUCTION.
- STOCKPILE MANAGEMENT TO BE IMPLEMENTED.
- DISTURBED AREA STABILIZED AS SOON AS POSSIBLE.

## PROJECT SPECIFICATIONS:

### GENERAL COMPACTION

- COMPACTION REQUIREMENTS AS SPECIFIED WILL BE BY PERCENT OF THE MAXIMUM DRY DENSITY AND AS DETERMINED PER ASTM D 1557.
- PLACE BACKFILL AND FILL SOIL MATERIAL IN LOOSE LIFTS OF NOT MORE THAN 8 INCHES FOR MATERIAL COMPACTED BY HEAVY EQUIPMENT, AND NOT MORE THAN 6 INCHES FOR MATERIAL COMPACTED BY HAND-OPERATED TAMPERS.
- THE GROUND SURFACE IN AREAS TO RECEIVE FILL SHALL BE PREPARED AS FOLLOWS:
  - ALL ORGANIC MATERIAL AND TOPSOIL SHALL BE REMOVED.
- ALL IMPROVEMENTS SHALL BE GRADED TO DRAIN TO THE APPROVED DRAINAGE COURSE AT A UNIFORM SLOPE OF 2% MINIMUM UNLESS OTHERWISE NOTED.
- THE CONTRACTOR SHALL BE RESPONSIBLE TO CONFIRM THE GROUND ELEVATIONS AND OVERALL TOPOGRAPHY OF THE SITE PRIOR TO THE START OF CONSTRUCTION. THE CONTRACTOR SHALL NOTIFY SHN CONSULTING ENGINEERS AT 707-441-8855 IMMEDIATELY, AND PROVIDE WRITTEN DESCRIPTION OF ANY DIFFERENCES IN TOPOGRAPHY FROM THAT SHOWN ON THESE PLANS WHICH MAY REQUIRE CHANGES IN DESIGN AND/OR AFFECT EARTHWORK QUANTITY.

### TESTING AND INSPECTION

- ALL SITE GRADING, SUBGRADE, AND BACKFILLING WILL BE INSPECTED BY THE ENGINEER. CONTRACTOR TO PROVIDE AT LEAST 48 HOUR NOTICE IN ADVANCE OF REQUIRED INSPECTION. FAILURE TO GIVE ADEQUATE NOTICE MAY RESULT IN TESTING DELAYS WHICH WILL BE THE RESPONSIBILITY OF THE CONTRACTOR.
- THE ENGINEER WILL PERFORM ALL COMPACTION TESTS WHEN ADVISED BY THE CONTRACTOR THAT IN THE OPINION OF THE CONTRACTOR, SUFFICIENT DENSITIES HAVE BEEN ACHIEVED. THE CONTRACTOR SHALL FURNISH A BACKHOE AND OPERATOR UPON REQUEST AT NO COST TO OWNER.
- THE CONTRACTOR SHALL MAKE ALL NECESSARY EXCAVATIONS FOR COMPACTION TESTS. COSTS OF EXCAVATION, BACKFILLING, AND COMPACTION IN CONNECTION WITH COMPACTION TESTING SHALL BE BORNE BY THE CONTRACTOR. A FAILING COMPACTION TEST INDICATES THAT THE REQUIRED COMPACTION STANDARDS HAVE NOT BEEN ACHIEVED. ANY FILL MATERIAL OR PORTION OF FILL MATERIAL THAT DOES NOT MEET THE SPECIFIED REQUIREMENTS SHALL BE REMOVED AND RECOMPACTED UNTIL THE REQUIREMENTS ARE SATISFIED AT NO ADDITIONAL COST TO THE OWNER. COSTS ASSOCIATED WITH RETESTING PREVIOUSLY FAILED AREAS SHALL BE PAID BY OWNER AND BACK-CHARGED TO THE CONTRACTOR.
- EXCAVATIONS FOR COMPACTION TESTS SHALL BE BACKFILLED WITH MATERIAL SIMILAR TO THAT EXCAVATED, AND BE COMPACTED TO THE SPECIFIED DENSITY.
- ALL COSTS ASSOCIATED WITH ACHIEVING COMPACTION STANDARDS SHALL BE INCLUDED IN THE BID PRICES PAID FOR THE BID ITEM INVOLVED AND THEREFORE NO ADDITIONAL COMPENSATION SHALL BE MADE.

### CONCRETE NOTES

- ALL CONCRETE CONSTRUCTION SHALL CONFORM WITH CHAPTER 19 OF THE CBC AND WITH THE PROVISIONS OF ACI 318.
- UNLESS OTHERWISE STATED, CONCRETE SHALL BE HARD ROCK CONCRETE AND SHALL MEET THE FOLLOWING DESIGN CRITERIA:
  - MINIMUM 28-DAY COMPRESSIVE STRENGTH = 3,000 PSI
  - MINIMUM CEMENT CONTENT = 5 SACKS/CUYD
  - MAXIMUM AGGREGATE SIZE = 3/4"
  - SLUMP = 4±1"
- REINFORCING SHALL BE PLACED IN ACCORDANCE WITH THE CONCRETE REINFORCING STEEL INSTITUTE (CRSI) "MANUAL OF STANDARD PRACTICE."
- ALL ITEMS TO BE CAST IN CONCRETE SUCH AS REINFORCING DOWELS, BOLTS, ANCHORS, PIPES AND SLEEVES SHALL BE SECURELY POSITIONED IN FORMS BEFORE PLACEMENT OF CONCRETE.
- ALL CONCRETE SHALL BE CURED PER ACI 308-16 STANDARDS.
- WHEN AIR TEMPERATURE IS ABOVE 80 DEGREES FAHRENHEIT, HOT WEATHER CONCRETING - ACI 305R - APPLIES. WHEN THE AVERAGE AIR TEMPERATURE IS BELOW 40 DEGREE FAHRENHEIT, COLD WEATHER CONCRETING - ACI 306R - APPLIES.
- THE CONTRACTOR SHALL REVIEW THE SLAB AND SLAB JOINT SPECIFICATIONS PRIOR TO CONCRETE PLACEMENT. SHN WILL NOT BE RESPONSIBLE FOR MITIGATION OF SLAB CRACKING THAT OCCURS OUTSIDE THE CRACK CONTROL GRID.

### REINFORCING STEEL

- ALL REINFORCING STEEL SHALL CONFORM TO ASTM A 615 GRADE 60 (A706 FOR REINF. TO BE WELDED).
- MINIMUM CLEAR DISTANCE BETWEEN EDGE OF REBAR AND THE NEAREST EXTERIOR EDGE OF THE CONCRETE SHALL BE AS FOLLOWS:
  - EXPOSED TO SOIL = 3" MIN
  - EXPOSED TO WEATHERING = 2" MIN
  - INTERIOR EXPOSURE ONLY 1-1/2" MIN
- MINIMUM DISTANCE BETWEEN REINFORCING STEEL SHALL BE NO LESS THAN THREE TIMES THE DIAMETER OF THE LARGEST AGGREGATE IN THE CONCRETE MIXTURE.
- PLACE 2-0 x 2-0 BARS AT CORNERS AND INTERSECTIONS.
- LAP ALL REINFORCING BARS MINIMUM 30" (UNLESS NOTED PER ACI 318-11).
- SECURELY TIE ALL REINFORCING PRIOR TO PLACING CONCRETE. ALL TIE WIRE SHALL BE Min. #16 ANNEALED STEEL.
- ALL REINFORCING STEEL SHALL BE DETAILED, FABRICATED, AND PLACED IN ACCORDANCE WITH CRSI MANUAL OF STANDARD PRACTICE, MSP 2009.
- ALL REINFORCING SHALL BE SUPPORTED ON WELL CURED CONCRETE BLOCKS OR APPROVED METAL CHAIRS, AS SPECIFIED BY THE CRSI MANUAL OF STANDARD PRACTICE, MSP 2009.
- WELDED WIRE FABRIC TO BE PER ASTM A185.



SAVED: 5/2/2024 9:35 AM CNEWELL, PLOTTED: 5/2/2024 9:42 AM NEWELL, CHRIS  
 P:\Willits\2021\421058-Noyo-CSP\101-Fish-Cleaning\Draws\421058-101-CMIL-SITE.dwg

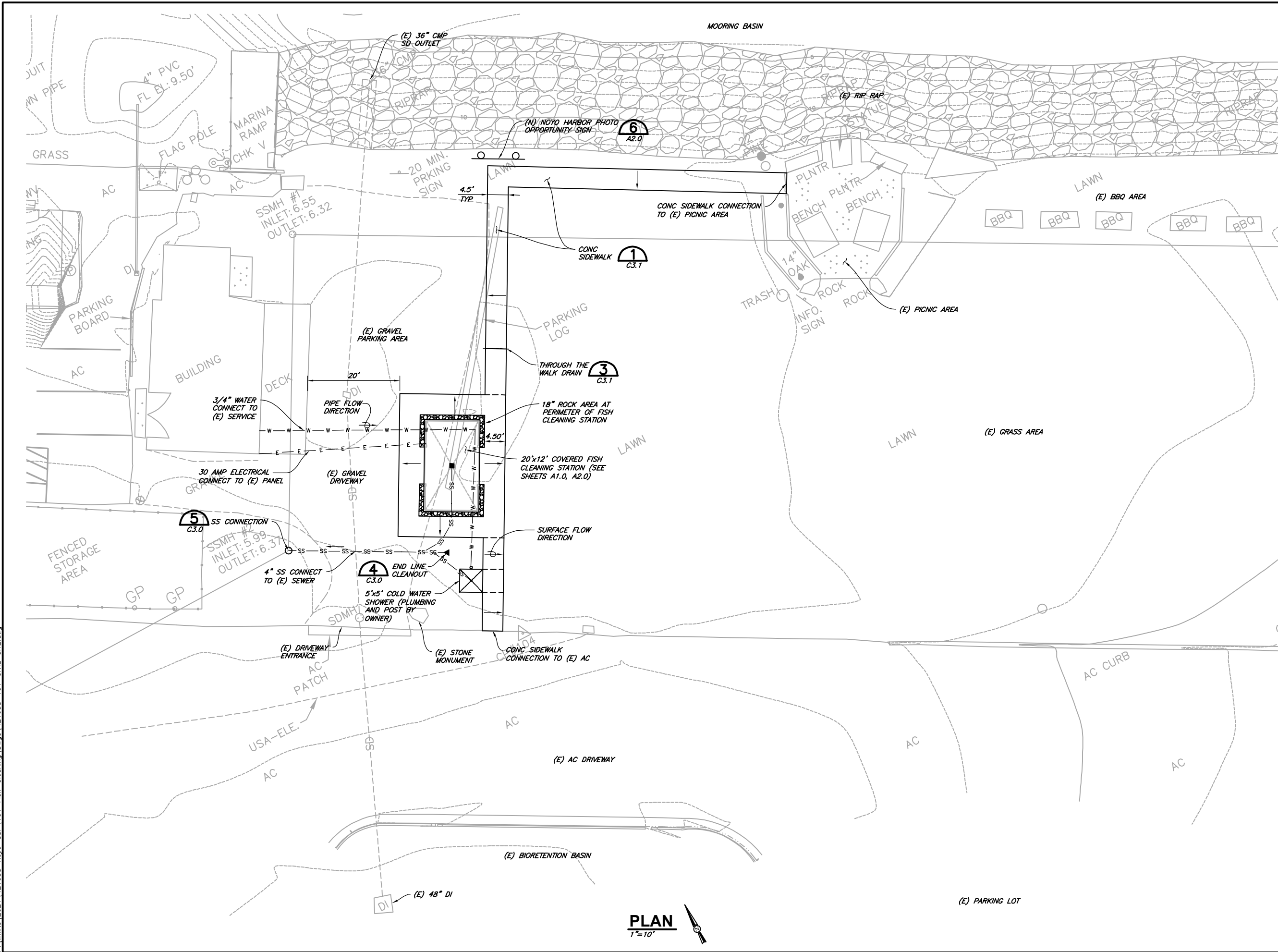

**PLAN**  
 1"=10'



VERIFY SCALES  
 BAR IS ONE INCH ON ORIGINAL DRAWING  
 0 1"  
 IF NOT ONE INCH ON SCALES ACCORDINGLY

535 S. MAIN ST  
 MILLIS, CA 94030  
 WWW.SQW.COM  
 707-459-4518



NO.	DATE	REVISION	BY

DSGN	JGI	DR	CON/JN	CHK	JGI	APVD	
NOYO HARBOR DISTRICT GRADER PARK FISH CLEANING STATION 19101 SOUTH HARBOR DR., FORT BRAGG, CALIFORNIA							
<b>SITE PLAN</b>							
SHEET	C1.0						
SEQ							
DATE	05/2024						
PROJ. NO.	421058.101						

5/2/2024



SAVED: 5/2/2024 9:37 AM CNEWELL, PLOTTED: 5/2/2024 9:42 AM NEWELL, CHRIS  
 P:\Willits\2021\421058-Noyo-CSP\101-Fish-Cleaning\Draws\421058-101-CMIL-GRDG.dwg

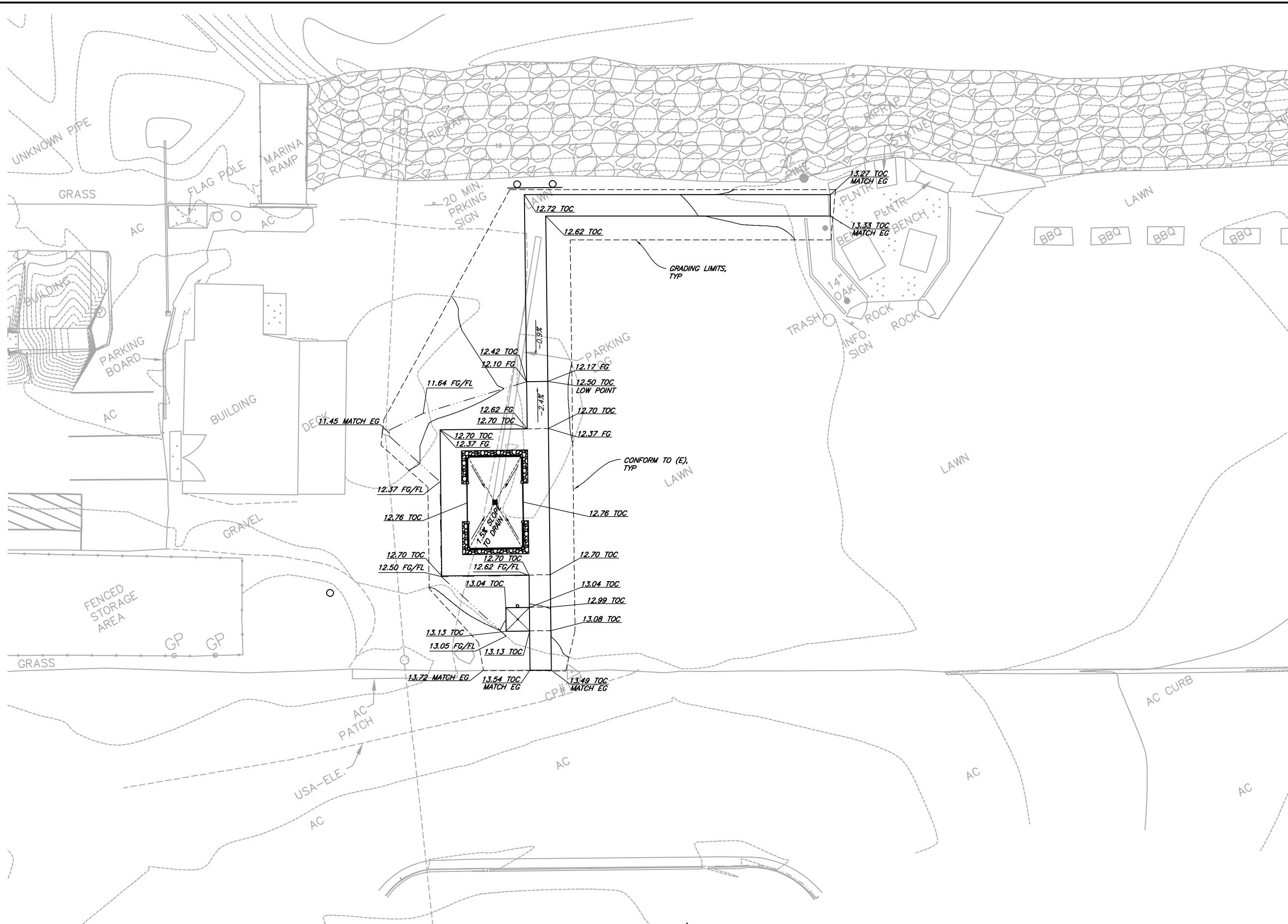

**PLAN**  
 1"=10'



VERIFY SCALES  
 BAR IS ONE INCH ON ORIGINAL DRAWING  
 0 IF NOT ONE INCH ON SCALES ACCORDINGLY

335 S. MAIN ST  
 SUITE 200  
 WILLITS, CA 95401  
 WWW.S&W-CORP.COM  
 707-459-4516



NO.	DATE	REVISION	BY

NOYO HARBOR DISTRICT GRADER PARK FISH CLEANING STATION 19101 SOUTH HARBOR DR., FORT BRAGG, CALIFORNIA	DRG JGI DR CON/JN CHK JGI APVD	SHEET <b>C2.0</b>
<b>GRADING PLAN</b>	DATE 05/2024	SEQ
	PROJ. NO. 421058.101	

5/2/2024



SAVED: 5/2/2024 9:40 AM CNEWELL, PLOTTED: 5/2/2024 9:42 AM NEWELL, CHRIS  
 P:\Willits\2021\421058-NOYO-CSP\101-Fish-Cleaning\Drawgs\421058-101-DTL5.dwg

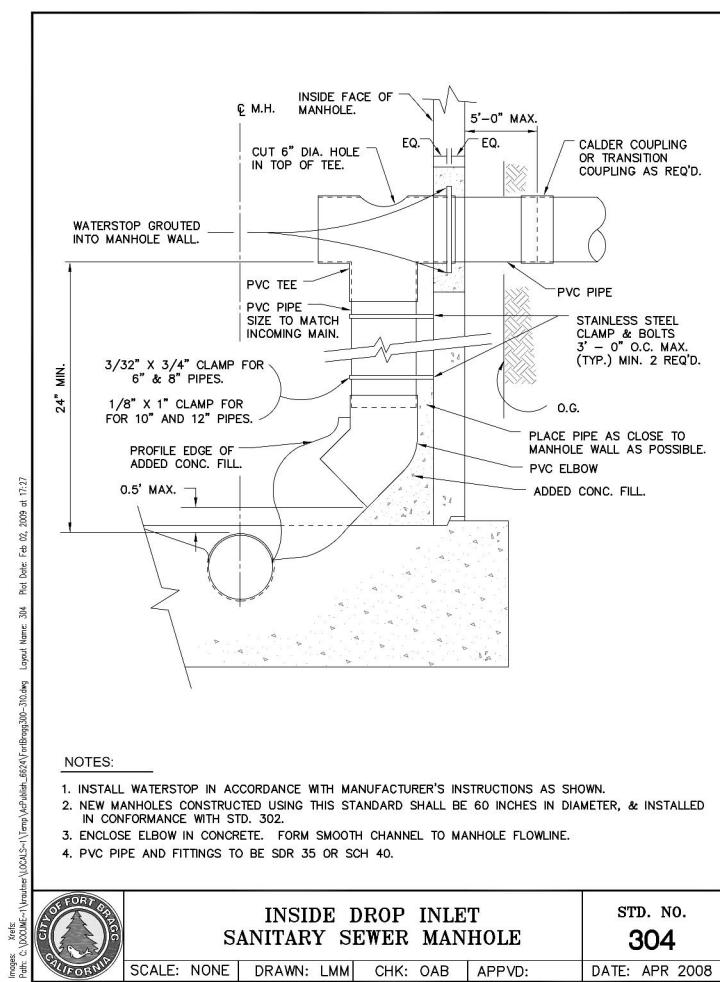
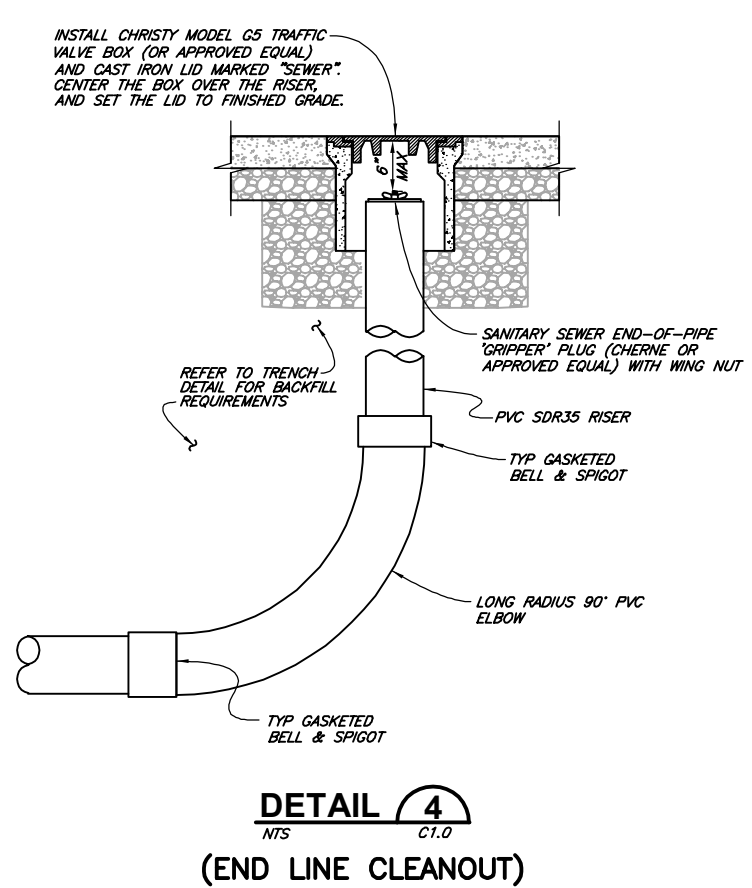
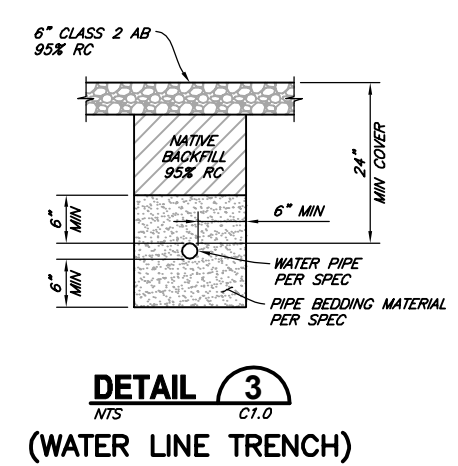
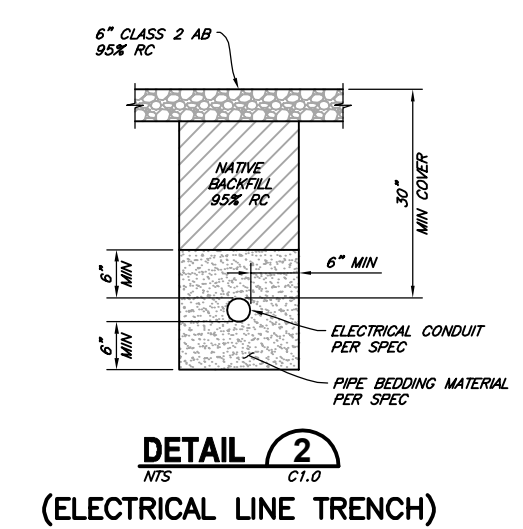
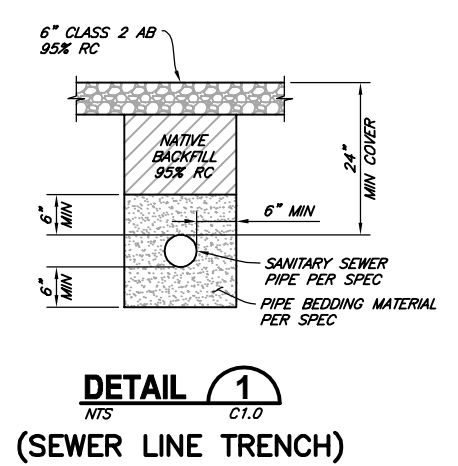

VERIFY SCALES  
 BAR IS ONE INCH ON ORIGINAL DRAWING  
 IF NOT ONE INCH ON SCALES ACCORDINGLY

335 S. MAIN ST. SUITE 200  
 FULLERTON, CA 92740  
 WWW.S&W-ENR.COM  
 707-459-4518

**S&W**

NO.	DATE	REVISION	BY

NOYO HARBOR DISTRICT  
 GRADER PARK FISH CLEANING STATION  
 19101 SOUTH HARBOR DR., FORT BRAGG, CALIFORNIA

**DETAILS**

DSGN	JGI
DR	CDN/JN
CHK	JGI
APPVD	

SHEET **C3.0**

SEQ

DATE 05/2024

PROJ. NO. 421058.101

5/2/2024

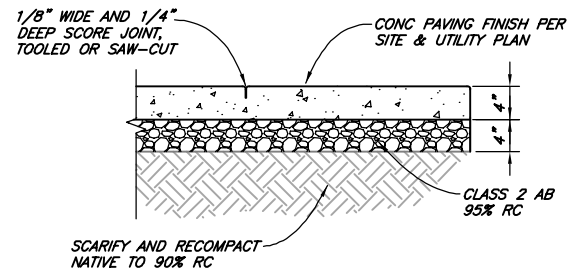

**NOTE:**  
PROVIDE SCORE JOINTS 10' OC UNLESS OTHERWISE NOTED.

**DETAIL 1**  
NTS C1.0, C3.2  
(CONCRETE SIDEWALK)

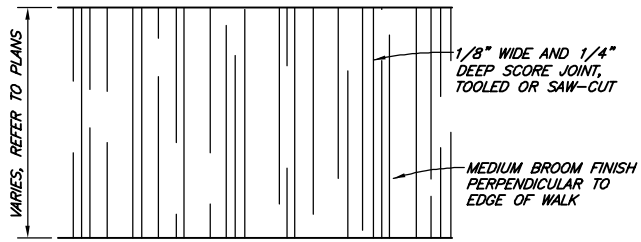

**NOTE:**  
PROVIDE SCORE JOINTS 10' OC UNLESS OTHERWISE NOTED.

**DETAIL 2**  
NTS C1.0  
(CONCRETE - SIDEWALK FINISH)

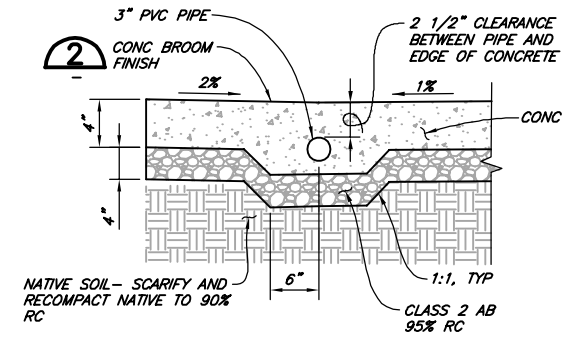

**DETAIL 3**  
NTS C1.0  
(THROUGH THE WALK DRAIN)

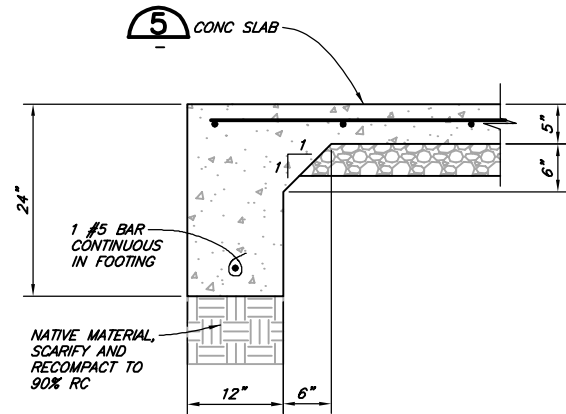

**DETAIL 4**  
NTS A1.0  
(THICKENED SLAB FOOTING)

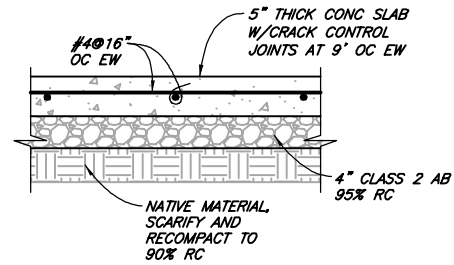

**DETAIL 5**  
NTS  
(CONCRETE SLAB)

SAVED: 5/2/2024 9:40 AM CNEWELL, PLOTTED: 5/2/2024 9:43 AM NEWELL, CHRIS  
P:\Willits\2021\421058-Noyo-CSP\101-Fish-Cleaning\Drawgs\421058-101-DTL5.dwg



VERIFY SCALES  
BAR IS ONE INCH ON ORIGINAL DRAWING  
IF NOT ONE INCH ON SCALES ACCORDINGLY

535 S. MAIN ST  
MILPITAS, CA 95030  
WWW.CESUR.COM  
707-459-4518



NO.	DATE	REVISION	BY

DR	CHK	APVD
JGI	JGI	JGI

NOYO HARBOR DISTRICT  
GRADER PARK FISH CLEANING STATION  
19101 SOUTH HARBOR DR., FORT BRAGG, CALIFORNIA

SHEET  
**C3.1**  
SEQ  
DATE 05/2024  
PROJ. NO. 421058.101

DETAILS

5/2/2024

SAVED: 5/2/2024 9:41 AM CNEWELL, PLOTTED: 5/2/2024 9:43 AM NEWELL, CHRIS  
 P:\Willits\2021\421058-Noyo-CSP\101-Fish-Cleaning\Draws\421058-101-ARCH.dwg

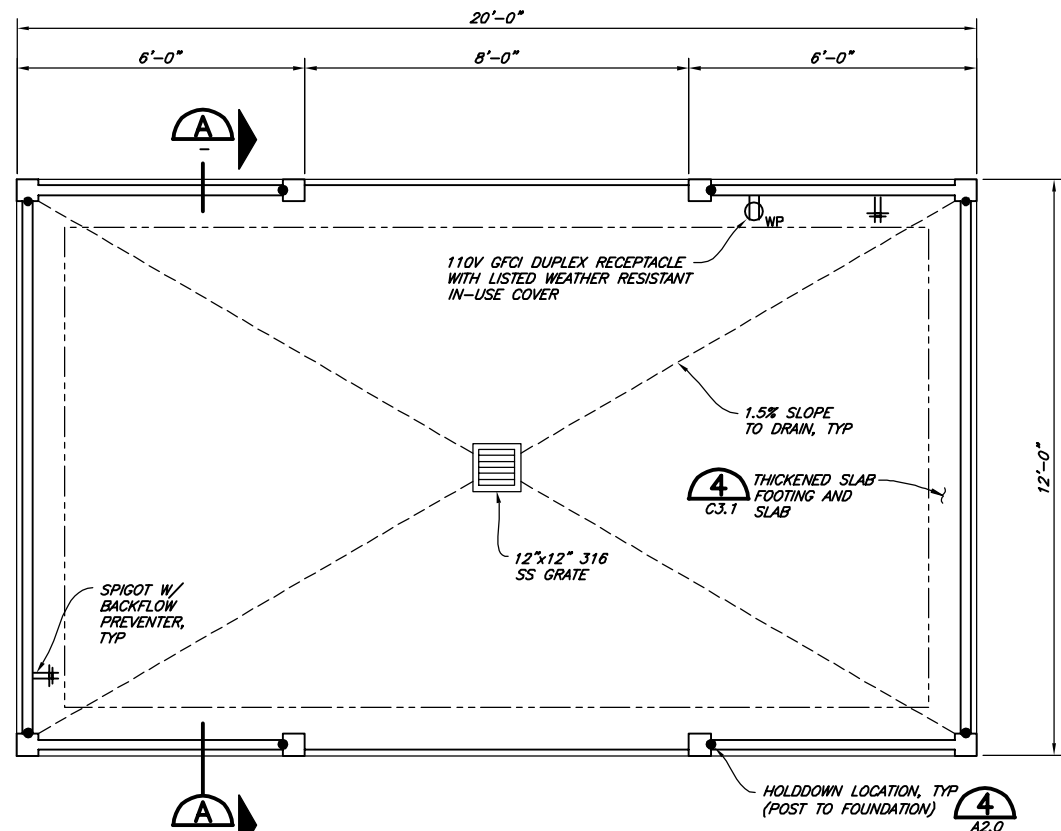

**FOUNDATION/ FLOOR PLAN**  
1/2"=1'-0"

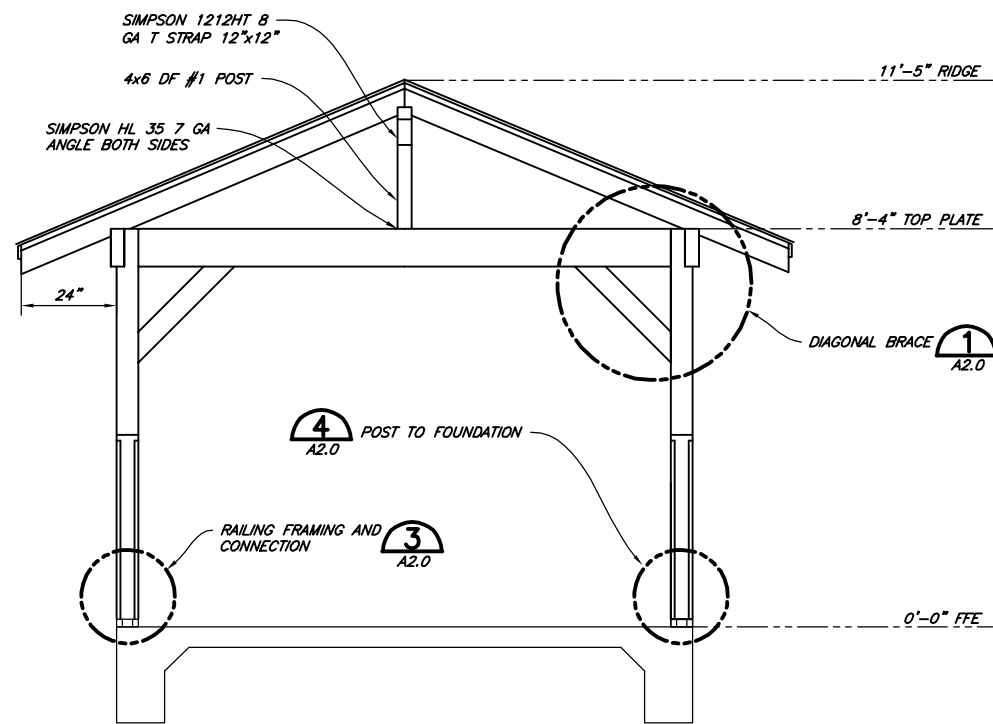

**SECTION A**  
1/2"=1'-0"

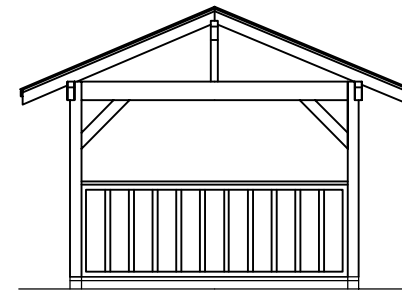

**NORTH**  
1/4"=1'-0"

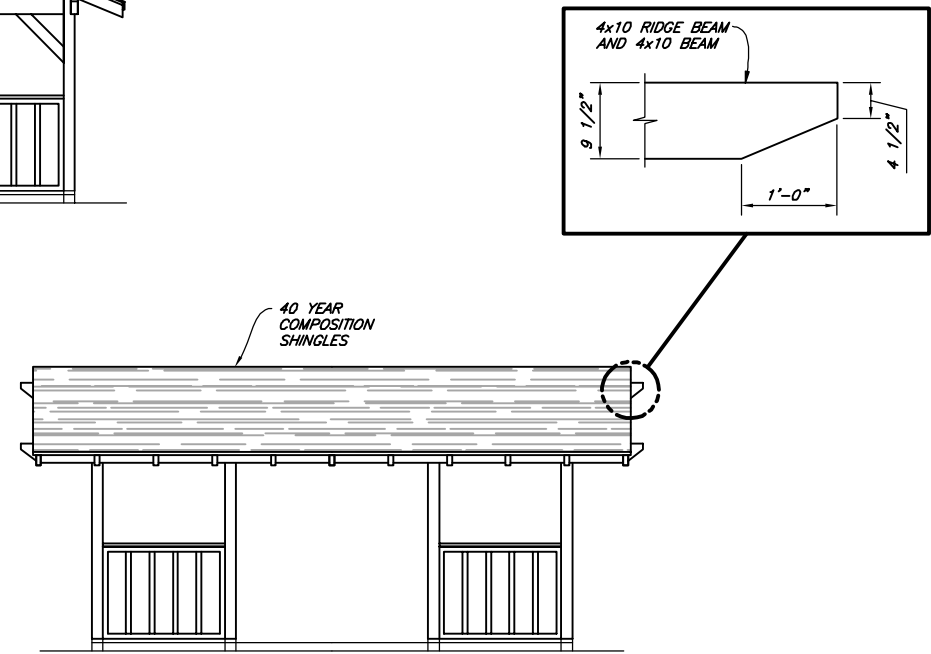

**WEST**  
1/4"=1'-0"

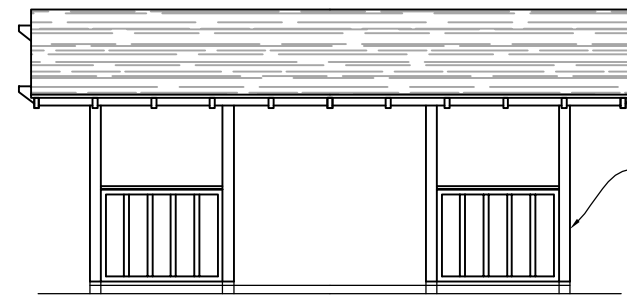

**EAST**  
1/4"=1'-0"

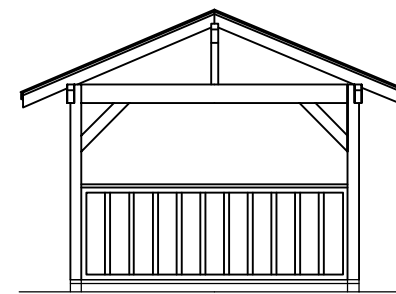

**SOUTH**  
1/4"=1'-0"



VERIFY SCALES  
 BAR IS ONE INCH ON ORIGINAL DRAWING  
 0 1"  
 IF NOT ONE INCH ON SCALES ACCORDINGLY

535 S. MAIN ST  
 MILPITAS, CA 95030  
 WWW.LULUENR.COM  
 707-459-4518



NO.	DATE	REVISION	BY

NOYO HARBOR DISTRICT  
 GRADER PARK FISH CLEANING STATION  
 19101 SOUTH HARBOR DR., FORT BRAGG, CALIFORNIA

**FLOOR PLAN AND ELEVATIONS**  
 SHEET  
**A1.0**  
 SEQ  
 DATE 05/2024  
 PROJ. NO. 421058.101  
 5/2/2024

SAVED: 5/2/2024 9:41 AM JINULTY, PLOTTED: 5/2/2024 9:43 AM NEWELL, CHRIS  
 P:\Willits\2021\421058-Noyo-CSP\101-Fish-Cleaning\Drawings\421058-101-ARCH-DETAIL.dwg

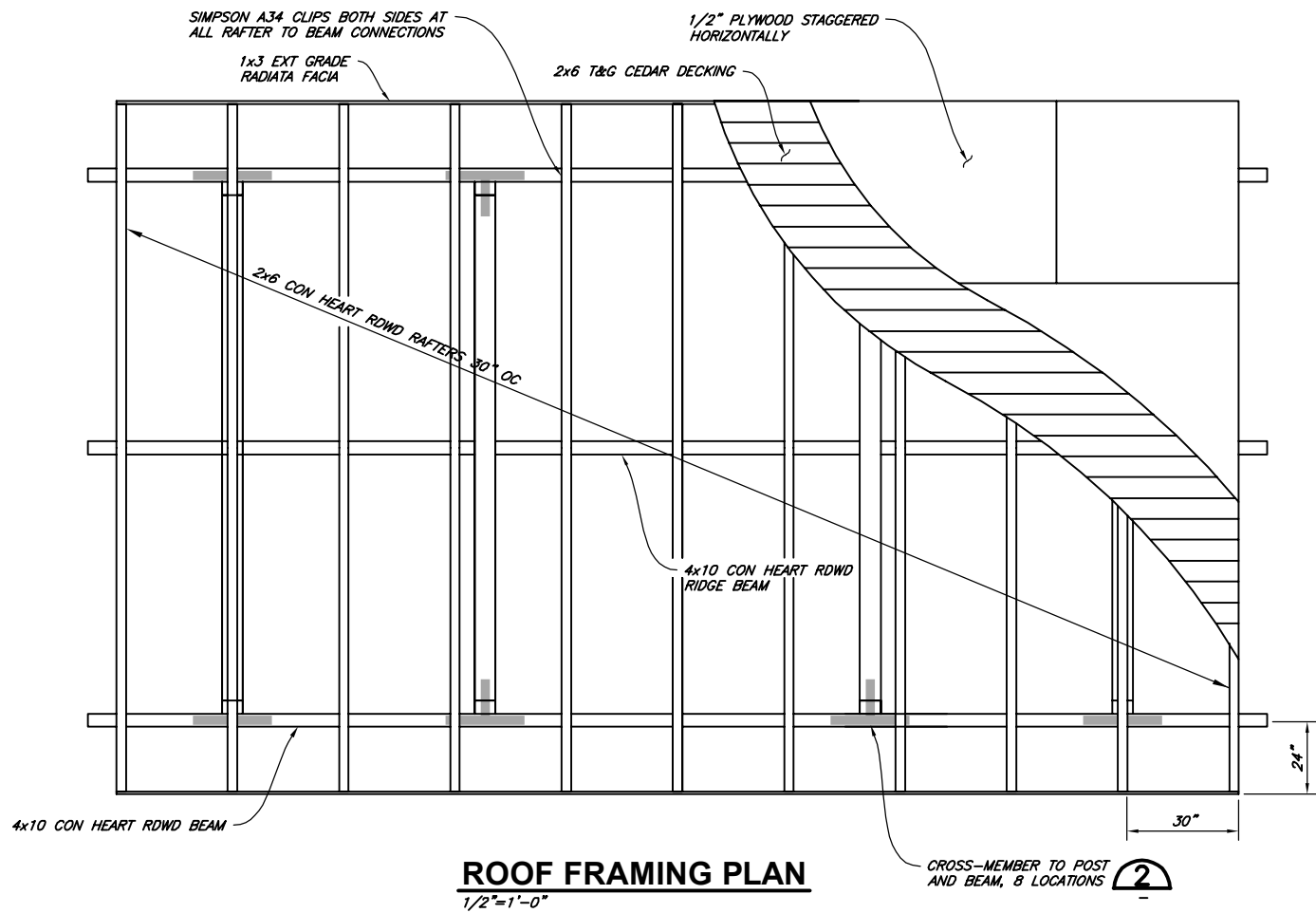

**ROOF FRAMING PLAN**  
1/2"=1'-0"

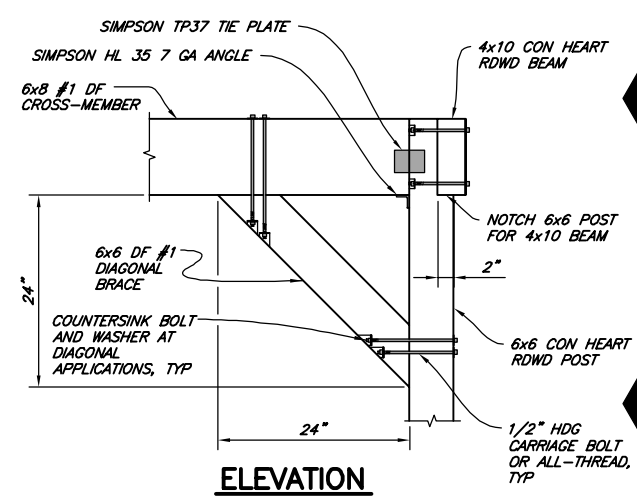

**DETAIL 1**  
1"=1'-0"  
(DIAGONAL BRACE)

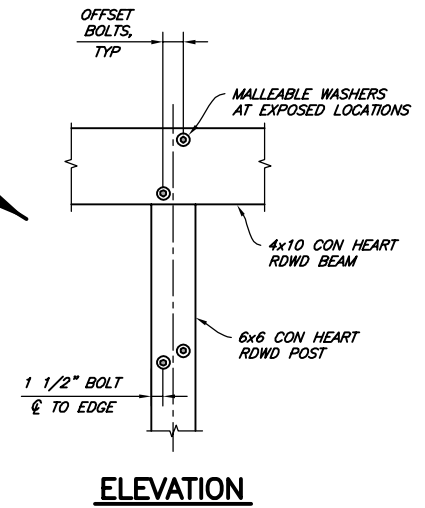

**ELEVATION**

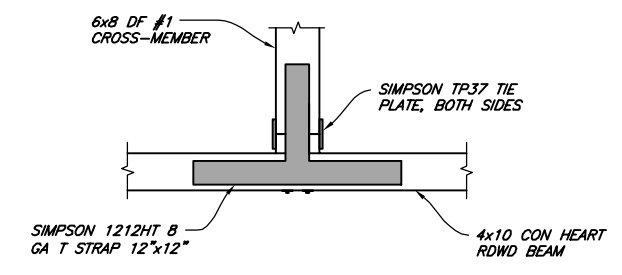

**DETAIL 2**  
1"=1'-0"  
(CROSS-MEMBER TO POST AND BEAM)

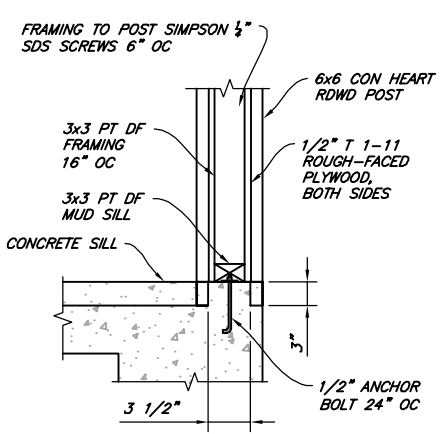

**DETAIL 3**  
1 1/2"=1'-0"  
(RAILING FRAMING AND CONNECTION)

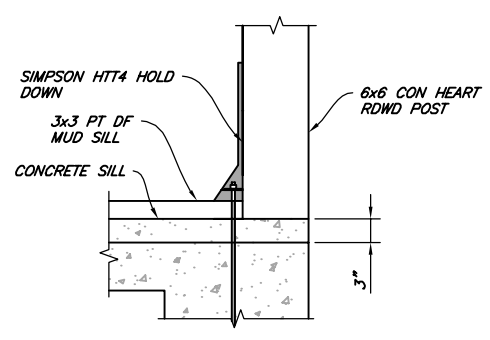

**DETAIL 4**  
1 1/2"=1'-0"  
(POST TO FOUNDATION)

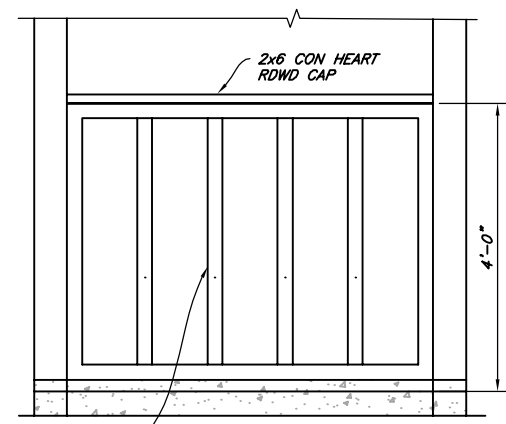

**DETAIL 5**  
1/2"=1'-0"  
(RAILING)

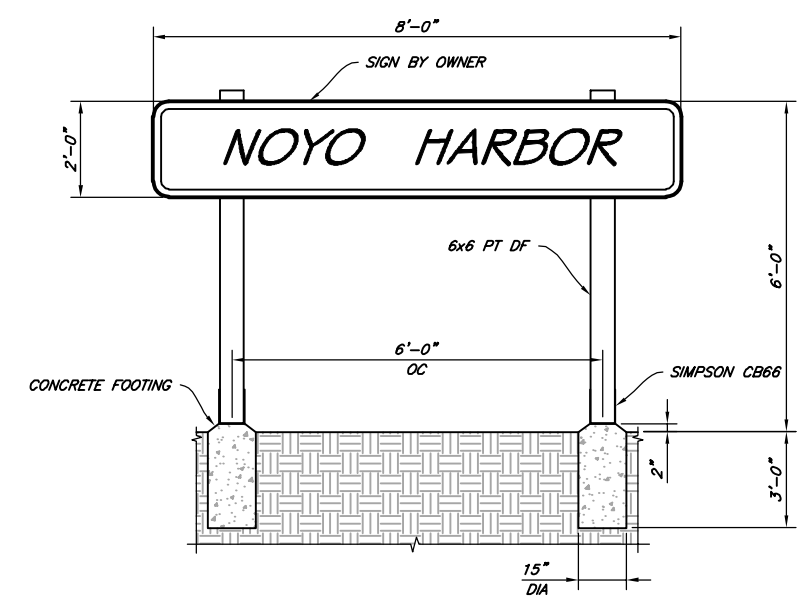

**DETAIL 6**  
NTS  
(SIGN & SIGN FOOTING)



VERIFY SCALES BAR IS ONE INCH ON ORIGINAL DRAWING IF NOT ONE INCH ON SCALES ACCORDINGLY	
535 S. MAIN ST. SUITE 200 WILLITS, CA 95400 WWW.WILLITSCONTRACTOR.COM 707-459-4515	
NO.	DATE
REVISION	BY
DSGN JGI DR CON/JN CHK JGI APVD	SHEET <b>A2.0</b> SEQ DATE 05/2024 PROJ. NO. 421058.101
NOYO HARBOR DISTRICT GRADER PARK FISH CLEANING STATION 19101 SOUTH HARBOR DR., FORT BRAGG, CALIFORNIA <b>ARCHITECTURAL DETAILS</b>	

**TABLE R602.3(1) FASTENING SCHEDULE**

ITEM	DESCRIPTION OF BUILDING ELEMENTS	NUMBER AND TYPE OF FASTENER <sup>a,b,c</sup>	SPACING AND LOCATION
<b>Roof</b>			
1	Blocking between ceiling joists, rafters or trusses to top plate or other framing below	4-8d box (2 1/2" x 0.113"); or 3-8d common (2 1/2" x 0.131"); or 3-10d box (3" x 0.128"); or 3-3" x 0.131" nails	Toe nail
	Blocking between rafters or truss not at the wall top plates, to rafter or truss	2-8d common (2 1/2" x 0.131"); or 2-3" x 0.131" nails	Each end toe nail
	Flat blocking to truss and web filler	2-16d common (3 1/2" x 0.162"); or 3" x 0.131" nails	End nail
2	Ceiling joists to top plate	4-8d box (2 1/2" x 0.113"); or 3-8d common (2 1/2" x 0.131"); or 3-10d box (3" x 0.128"); or 3-3" x 0.131" nails	Per joist, toe nail
	Ceiling joist not attached to parallel rafter, laps over partitions [see Section R802.5.2 and Table R802.5.2(1)]	4-10d box (3" x 0.128"); or 3-16d common (3 1/2" x 0.162"); or 4-3" x 0.131" nails	Face nail
4	Ceiling joist attached to parallel rafter (heel joint) [see Section R802.5.2 and Table R802.5.2(1)]	Table R802.5.2(1)	Face nail
5	Collar tie to rafter, face nail	4-10d box (3" x 0.128"); or 3-10d common (3" x 0.148"); or 4-3" x 0.131" nails	Face nail each rafter
6	Rafter or roof truss to plate	3-16d box (3 1/2" x 0.135"); or 3-10d common (3" x 0.148"); or 4-10d box (3" x 0.128"); or 4-3" x 0.131" nails	2 toe nails on one side and 1 toe nail on opposite side of each rafter or truss
7	Roof rafters to ridge, valley or hip rafters or roof rafter to minimum 2" ridge beam	4-16d box (3 1/2" x 0.135"); or 3-10d common (3" x 0.148"); or 4-10d box (3" x 0.128"); or 4-3" x 0.131" nails	Toe nail
		3-16d box (3 1/2" x 0.135"); or 2-16d common (3 1/2" x 0.162"); or 3-10d box (3" x 0.128"); or 3-3" x 0.131" nails	End nail
<b>Wall</b>			
8	Stud to stud (not at braced wall panels)	16d common (3 1/2" x 0.162"); or 10d box (3" x 0.128"); or 3" x 0.131" nails	24" o.c. face nail
	Stud to stud and abutting studs at intersecting wall corners (at braced wall panels)	16d common (3 1/2" x 0.162"); or 3" x 0.131" nails	16" o.c. face nail
9	Stud to stud and abutting studs at intersecting wall corners (at braced wall panels)	16d common (3 1/2" x 0.162"); or 3" x 0.131" nails	12" o.c. face nail
10	Built-up header (2" to 2" header with 1/2" spacer)	16d common (3 1/2" x 0.162"); or 16d box (3 1/2" x 0.135")	16" o.c. each edge face nail
11	Continuous header to stud	5-8d box (2 1/2" x 0.113"); or 4-8d common (2 1/2" x 0.131"); or 4-10d box (3" x 0.128")	Toe nail

(continued)

**TABLE R602.3(1)—continued FASTENING SCHEDULE**

ITEM	DESCRIPTION OF BUILDING ELEMENTS	NUMBER AND TYPE OF FASTENER <sup>a,b,c</sup>	SPACING AND LOCATION
<b>Wall</b>			
12	Adjacent full-height stud to end of header	4-16d box (3 1/2" x 0.135"); or 3-16d common (3 1/2" x 0.162"); or 4-10d box (3" x 0.128"); or 4-3" x 0.131" nails	End nail
13	Top plate to top plate	16d common (3 1/2" x 0.162"); or 10d box (3" x 0.128"); or 3" x 0.131" nails	16" o.c. face nail
14	Double top plate splice	8-16d common (3 1/2" x 0.162"); or 12-16d box (3 1/2" x 0.135"); or 12-10d box (3" x 0.128"); or 12-3" x 0.131" nails	Face nail on each side of end joint (minimum 24" lap splice length each side of end joint)
	Bottom plate to joist, rim joist, band joist or blocking (not at braced wall panels)	16d common (3 1/2" x 0.162"); or 16d box (3 1/2" x 0.135"); or 3" x 0.131" nails	16" o.c. face nail
<b>Roof</b>			
16	Bottom plate to joist, rim joist, band joist or blocking (at braced wall panel)	3-16d box (3 1/2" x 0.135"); or 2-16d common (3 1/2" x 0.162"); or 4-3" x 0.131" nails	16" o.c. face nail
17	Top or bottom plate to stud	4-8d box (2 1/2" x 0.113"); or 3-16d box (3 1/2" x 0.135"); or 4-8d common (2 1/2" x 0.131"); or 4-10d box (3" x 0.128"); or 4-3" x 0.131" nails	Toe nail
		3-16d box (3 1/2" x 0.135"); or 2-16d common (3 1/2" x 0.162"); or 3-10d box (3" x 0.128"); or 3-3" x 0.131" nails	End nail
18	Top plates, laps at corners and intersections	3-10d box (3" x 0.128"); or 2-16d common (3 1/2" x 0.162"); or 3-3" x 0.131" nails	Face nail
19	1" brace to each stud and plate	3-8d box (2 1/2" x 0.113"); or 2-8d common (2 1/2" x 0.131"); or 2-10d box (3" x 0.128"); or 2 staples 1 1/2"	Face nail
20	1" x 6" sheathing to each bearing	3-8d box (2 1/2" x 0.113"); or 2-8d common (2 1/2" x 0.131"); or 2-10d box (3" x 0.128"); or 2 staples, 1" crown, 16 ga., 1 1/2" long	Face nail
		3-8d box (2 1/2" x 0.113"); or 3-8d common (2 1/2" x 0.131"); or 3-10d box (3" x 0.128"); or 3 staples, 1" crown, 16 ga., 1 1/2" long	Face nail
21	1" x 8" and wider sheathing to each bearing	Wider than 1" x 8" 4-8d box (2 1/2" x 0.113"); or 3-8d common (2 1/2" x 0.131"); or 3-10d box (3" x 0.128"); or 4 staples, 1" crown, 16 ga., 1 1/2" long	Face nail

(continued)

For SI: 1 inch = 25.4 mm, 1 foot = 304.8 mm, 1 mile per hour = 0.447 m/s; 1 ksi = 6.895 MPa.

a. Nails are smooth-common, box or deformed shanks except where otherwise stated. Nails used for framing and sheathing connections are carbon steel and shall have minimum average bending yield strengths as shown: 90 ksi for shank diameter of 0.192 inch (20d common nail), 90 ksi for shank diameters larger than 0.142 inch but not larger than 0.177 inch, and 100 ksi for shank diameters of 0.142 inch or less. Connections using nails and staples of other materials, such as stainless steel, shall be designed by accepted engineering practice or approved under Section R104.11.

b. RSRS-01 is a Roof Sheathing Ring Shank nail meeting the specifications in ASTM F1667.

c. Nails shall be spaced at not more than 6 inches on center at all supports where spans are 48 inches or greater.

d. Four-foot by 8-foot or 4-foot by 9-foot panels shall be applied vertically.

e. Spacing of fasteners not included in this table shall be based on Table R602.3(2).

f. For wood structural panel roof sheathing attached to gable end roof framing and to intermediate supports within 48 inches of roof edges and ridges, nails shall be spaced at 4 inches on center where the ultimate design wind speed is greater than 130 mph in Exposure B or greater than 110 mph in Exposure C.

g. Gypsum sheathing shall conform to ASTM C1396 and shall be installed in accordance with ASTM C1289 or GA 253. Fiberboard sheathing shall conform to ASTM C208.

h. Spacing of fasteners on floor sheathing panel edges applies to panel edges supported by framing members and required blocking and at floor perimeters only. Spacing of fasteners on roof sheathing panel edges applies to panel edges supported by framing members and required blocking. Blocking of roof or floor sheathing panel edges perpendicular to the framing members need not be provided except as required by other provisions of this code. Floor perimeter shall be supported by framing members or solid blocking.

i. Where a rafter is fastened to an adjacent parallel ceiling joist in accordance with this schedule, provide two toe nails on one side of the rafter and toe nails from the ceiling joist to top plate in accordance with this schedule. The toe nail on the opposite side of the rafter and toe nails from the ceiling joist to top plate in accordance with this schedule. The toe nail on the opposite side of the rafter and toe nails from the ceiling joist to top plate in accordance with this schedule. The toe nail on the opposite side of the rafter and toe nails from the ceiling joist to top plate in accordance with this schedule.

**TABLE R602.3(1)—continued FASTENING SCHEDULE**

ITEM	DESCRIPTION OF BUILDING ELEMENTS	NUMBER AND TYPE OF FASTENER <sup>a,b,c</sup>	SPACING AND LOCATION
<b>Other wall sheathing<sup>d</sup></b>			
34	1/2" structural cellulose fiberboard sheathing	1 1/2" x 0.120" galvanized roofing nail, 3/8" head diameter, or 1 1/2" long 16 ga. staple with 7/16" or 1" crown	3 6
35	3/8" structural cellulose fiberboard sheathing	1 1/2" x 0.120" galvanized roofing nail, 3/8" head diameter, or 1 1/2" long 16 ga. staple with 7/16" or 1" crown	3 6
36	1/2" gypsum sheathing <sup>e</sup>	1 1/2" x 0.120" galvanized roofing nail, 3/8" head diameter, or 1 1/2" long 16 ga.; staple galvanized, 1 1/2" long, 7/16" or 1" crown or 1 1/2" screws, Type W or S	7 7
37	3/4" gypsum sheathing <sup>e</sup>	1 1/2" x 0.120" galvanized roofing nail, 3/8" head diameter, or 1 1/2" long 16 ga.; staple galvanized, 1 1/2" long, 7/16" or 1" crown or 1 1/2" screws, Type W or S	7 7
<b>Wood structural panels, combination subfloor underlayment to framing</b>			
38	1/2" and less	Deformed (2" x 0.113") or Deformed (2" x 0.120") nail; or 8d common (2 1/2" x 0.131") nail	6 12
39	3/4" - 1"	8d common (2 1/2" x 0.131") nail; or Deformed (2" x 0.113"); or Deformed (2 1/2" x 0.120") nail	6 12
40	1 1/2" - 1 3/4"	10d common (3" x 0.148") nail; or Deformed (2" x 0.113"); or Deformed (2 1/2" x 0.120") nail	6 12

**TABLE R602.3(1)—continued FASTENING SCHEDULE**

ITEM	DESCRIPTION OF BUILDING ELEMENTS	NUMBER AND TYPE OF FASTENER <sup>a,b,c</sup>	SPACING AND LOCATION
<b>Floor</b>			
22	Joist to sill, top plate or girder	4-8d box (2 1/2" x 0.113"); or 3-8d common (2 1/2" x 0.131"); or 3-10d box (3" x 0.128"); or 3-3" x 0.131" nails	Toe nail
	Rim joist, band joist or blocking to sill or top plate (roof applications also)	8d box (2 1/2" x 0.113")	4" o.c. toe nail
23	1" x 6" subfloor or less to each joist	8d common (2 1/2" x 0.131"); or 10d box (3" x 0.128"); or 3" x 0.131" nails	6" o.c. toe nail
		3-8d box (2 1/2" x 0.113"); or 2-8d common (2 1/2" x 0.131"); or 3-10d box (3" x 0.128"); or 2 staples, 1" crown, 16 ga., 1 1/2" long	Face nail
24	2" subfloor to joist or girder	3-16d box (3 1/2" x 0.135"); or 2-16d common (3 1/2" x 0.162")	Blind and face nail
25	2" planks (plank & beam—floor & roof)	3-16d box (3 1/2" x 0.135"); or 2-16d common (3 1/2" x 0.162")	At each bearing, face nail
26	Band or rim joist to joist	3-16d common (3 1/2" x 0.162"); or 4-10 box (3" x 0.128"); or 4-3" x 0.131" nails; or 4-3" x 14 ga. staples, 7/16" crown	End nail
		20d common (4" x 0.192"); or 10d box (3" x 0.128"); or 3" x 0.131" nails	Nail each layer as follows: 32" o.c. at top and bottom and staggered.
27	Built-up girders and beams, 2-inch lumber layers	And: 2-20d common (4" x 0.192"); or 3-10d box (3" x 0.128"); or 3-3" x 0.131" nails	24" o.c. face nail at top and bottom staggered on opposite sides
		4-16d box (3 1/2" x 0.135"); or 3-16d common (3 1/2" x 0.162"); or 4-10d box (3" x 0.128"); or 4-3" x 0.131" nails	Face nail at ends and at each splice
28	Ledger strip supporting joists or rafters	2-10d box (3" x 0.128"); or 2-8d common (2 1/2" x 0.131"); or 2-3" x 0.131" nails	At each joist or rafter, face nail
29	Bridging or blocking to joist, rafter or truss	2-10d box (3" x 0.128"); or 2-8d common (2 1/2" x 0.131"); or 2-3" x 0.131" nails	Each end, toe nail
<b>SPACING OF FASTENERS</b>			
ITEM	DESCRIPTION OF BUILDING ELEMENTS	NUMBER AND TYPE OF FASTENER <sup>a,b,c</sup>	Edges <sup>d</sup> (inches)
			Intermediate supports <sup>e</sup> (inches)
<b>Wood structural panels, subfloor, roof and interior wall sheathing to framing and particleboard wall sheathing to framing [see Table R602.3(2) for wood structural panel exterior wall sheathing to wall framing]</b>			
31	3/8" - 1/2"	6d common or deformed (2" x 0.113" x 0.266" head); or 2 1/2" x 0.113" x 0.266" head nail (subfloor, wall)	6 6'
			6 6'
32	3/8" - 1/2"	8d common (2 1/2" x 0.131") nail (roof); or RSRS-01 (2 1/2" x 0.113") nail (roof) (subfloor, wall)	6 12
			6 6'
33	3/8" - 1 1/4"	Deformed 2 1/2" x 0.113" x 0.266" head (wall or subfloor)	6 12
			6 12

(continued)



NOYO HARBOR DISTRICT  
 GRADER PARK FISH CLEANING STATION  
 SOUTH HARBOR DR., FORT BRAGG, CALIFORNIA  
 19101

**FASTENING SCHEDULE**

SHEET  
**S1.0**  
 SEQ  
 DATE **05/2024**  
 PROJ. NO. **421058.101**

5/2/2024

NO. DATE REVISION BY

JGI SRH JGI APVD

335 S. MAIN ST. SUITE 500  
 WILKINS, CALIFORNIA 94993  
 WWW.WILKINS-CSP.COM  
 707-459-4516

VERIFY SCALES  
 BAR IS ONE INCH ON ORIGINAL DRAWING  
 0 1"  
 IF NOT ONE INCH ON SCALES ACCORDINGLY



**Page Left Blank**





# NOYO HARBOR DISTRICT AGENDA ITEM SUMMARY

**AGENDA ITEM #: 4**  
**MEETING DATE: 5/9/2024**

## TITLE

Draft Budget

## RECOMMENDED ACTION

Recommendations

## ANALYSIS

The attached budget is the draft budget for the 2024/2025 fiscal year. The projected revenues/expenses 2023/2024 are based on actual expenditures and revenues from July 1, 2023 through March 31<sup>st</sup>, 2024. The Interest Income Property Tax categories are the actual revenues for the 2023/2024 year and no more income will be seen in these categories.

The Harbormaster added in a new “revenue” category for the Economic Development Department grant. Within the Budget for this grant the District will be reimbursed for staff time and indirect cost of operations.

Under the grant information page, the Harbormaster added narratives that detailed the grants impact on District general funds. Hopefully, this page gives a better insight as to actual impacts of grants on the District.

## FISCAL IMPACT

## ATTACHMENTS

Proposed Budget 2024/2025



**Page Left Blank**



Noyo Harbor District (NHD)

	<b>Budget 2020/2021</b>	<b>Budget 2021/2022</b>	<b>Budget 2022/2023</b>	<b>Budget 2023/2024</b>	<b>Projected Revenues 2023/2024</b>	<b>Proposed Budget 2024/2025</b>
<b>Revenues</b>						
Slip Rental - Contract	550,000.00	525,000.00	650,000.00	456,000.00	429,340.00	433,000.00
Slip Rental - Transient	65,000.00	50,000.00	60,000.00	43,000.00	48,257.00	45,000.00
Hoist Fees	0.00	3,000.00	1,000.00	1,000.00	200.00	500.00
Park & Launch	25,000.00	30,000.00	35,000.00	25,000.00	41,032.00	35,000.00
Main Pier	0.00	0.00	0.00	1,000.00	0.00	0.00
Ground Rent	30,000.00	30,000.00	40,000.00	30,000.00	2,478.00	20,000.00
Encroachment Leases	20,000.00	20,000.00	20,000.00	20,000.00	24,759.00	25,000.00
Electric	0.00	0.00	15,000.00	10,000.00	13,890.00	15,000.00
Late Fees	600.00	3,000.00	4,000.00	2,000.00	2,778.00	2,000.00
<b>Income -Marina Based</b>	<b>690,600.00</b>	<b>661,000.00</b>	<b>825,000.00</b>	<b>588,000.00</b>	<b>562,734.00</b>	<b>575,500.00</b>
Community Fish Markets	25,000.00	5,000.00	3,000.00	3,000.00	2,362.00	2,000.00
Property Tax Rev-Current	102,000.00	112,000.00	117,000.00	117,260.00	130,807.67	117,000.00
Interest Income	3,000.00	5,000.00	4,830.00	30,000.00	49,433.58	48,000.00
Local Coastal Program Update- City Of Fort Bragg				20,000.00	200	30,000.00
Economic Development Department						40,000.00
<b>Other Revenues</b>	<b>130,000.00</b>	<b>122,000.00</b>	<b>124,830.00</b>	<b>170,260.00</b>	<b>182,803.25</b>	<b>237,000.00</b>
<b>Total Revenues</b>	<b>820,600.00</b>	<b>783,000.00</b>	<b>949,830.00</b>	<b>758,260.00</b>	<b>745,537.25</b>	<b>812,500.00</b>

<b>Expenses</b>	<b>Budget 2020/2021</b>	<b>Budget 2021/2022</b>	<b>Budget 2022/2023</b>	<b>Budget 2023/2024</b>	<b>Projected Expense 2023/2024</b>	<b>Proposed Budget 2024/2025</b>
<b>Payroll and Employee Burdens</b>						
Harbormaster	60,000.00	60,000.00	60,000.00	70,000.00	68,700.00	70,000.00
Wages Hourly 2 F.T. 2 P.T.	95,000.00	95,000.00	137,696.00	116,000.00	106,272.00	160,000.00
Emp. Health & Dental Insurance	85,000.00	85,000.00	25,000.00	24,000.00	28,722.00	30,000.00
Sep. Ira	18,000.00	20,000.00	15,000.00	8,100.00	8,356.00	16,000.00
Payroll Tax Expense	30,000.00	31,500.00	31,000.00	17,000.00	13,840.00	18,400.00
<b>Employee Totals</b>	<b>288,000.00</b>	<b>291,500.00</b>	<b>268,696.00</b>	<b>235,100.00</b>	<b>225,890.00</b>	<b>294,400.00</b>
<b>Utilites</b>						
Utilities Expense (Trash/Water)			90,000.00	68,000.00	63,595.00	65,000.00
Power			55,000.00	55,000.00	56,499.00	57,000.00
<b>Utilities</b>	<b>115,000.00</b>	<b>130,000.00</b>	<b>145,000.00</b>	<b>123,000.00</b>	<b>120,094.00</b>	<b>122,000.00</b>
<b>Insurance Property &amp; Liability</b>	<b>193,000.00</b>	<b>195,000.00</b>	<b>210,000.00</b>	<b>210,000.00</b>	<b>218,652.00</b>	<b>230,000.00</b>
<b>Legal and Professional Fees</b>						
Legal	15,000.00	15,000.00	35,000.00	24,000.00	16,450.00	20,000.00
Consultant	10,000.00	10,000.00	20,000.00	25,000.00	18,776.00	20,000.00
Auditor	3,500.00	8,000.00	10,000.00	8,500.00	4,025.00	8,500.00
<b>Legal and Professional Totals</b>	<b>28,500.00</b>	<b>33,000.00</b>	<b>65,000.00</b>	<b>57,500.00</b>	<b>39,251.00</b>	<b>48,500.00</b>

	Budget 2020/2021	Budget 2021/2022	Budget 2022/2023	Budget 2023/2024	Projected Expense 2023/2024	Proposed Budget 2024- 2025
<b>Office and Admin Expenses</b>						
Office Expense	6,000.00	6,000.00	6,000.00	11,000.00	8,454.00	10,000.00
Office Equipment	1,500.00	1,500.00	1,500.00	800.00	760.00	800.00
Conferences & Meetings	0.00	5,000.00	5,000.00	5,000.00	1,750.00	2,000.00
Dues and Subscriptions Exp	2,000.00	3,000.00	12,000.00	10,000.00	12,474.00	13,000.00
Advertising Expense	500.00	500.00	3,000.00	800.00	332.00	500.00
Communications Expense	3,000.00	3,000.00	3,000.00	4,500.00	4,528.00	4,500.00
Taxes & Assessments	25,000.00	32,000.00	3,000.00	3,000.00	1,472.00	2,000.00
Refunds				1,000.00	942.00	1,000.00
<b>Office and Admin Expenses</b>	<b>26,500.00</b>	<b>26,500.00</b>	<b>33,500.00</b>	<b>36,100.00</b>	<b>30,712.00</b>	<b>33,800.00</b>
<b>Grounds</b>						
Repairs & Maintenance	35,000.00	35,000.00	45,000.00	28,000.00	29,301.44	33,000.00
Operating Supplies	9,000.00	9,000.00	9,000.00	7,000.00	5,412.00	6,000.00
Equipment Purchase	2,000.00	10,000.00	4,000.00	0.00		1,000.00
Equipment Expense	1,000.00	3,000.00	1,000.00	0.00		
Fuel Expense	3,000.00	1,500.00	1,600.00	5,000.00	3,285.00	5,000.00
Deferred Maintenance	35,000.00	65,000.00	30,000.00	10,000.00		10,000.00
<b>Maintenance &amp; Repairs</b>	<b>85,000.00</b>	<b>123,500.00</b>	<b>90,600.00</b>	<b>50,000.00</b>	<b>37,998.44</b>	<b>55,000.00</b>
<b>Grant Expenses</b>						
Save Grant	0.00	0.00	13,000.00	10,000.00	2,271.45	2,000.00
<b>Grant Expenses</b>	<b>0.00</b>	<b>0.00</b>	<b>13,000.00</b>	<b>10,000.00</b>	<b>2,271.45</b>	<b>2,000.00</b>
<b>Total Expenses</b>	<b>736,000</b>	<b>799,500</b>	<b>825,796</b>	<b>721,700</b>	<b>674,869</b>	<b>785,700</b>
<b>Net Income</b>	<b>84,600</b>	<b>(16,500)</b>	<b>124,034</b>	<b>36,560.00</b>	<b>70,668.36</b>	<b>26,800.00</b>

**Active Grants**

<b>SAVE Grant 2022/2023</b>	Total Award	Remaining	Match	Remaining Match	2024/2025 Yearly Impact
End Date: 9/30/2024	\$80,000.00	\$40,650.00	\$8,000.00	\$4,065.00	-\$2,000.00

<b>State Lands Commission</b>	Total Award	Remaining	Match	Remaining Match	2024/2025 Yearly Impact
End Date: 10/2026	\$448,808.00	\$131,919.21	\$0.00	\$0.00	\$0

<b>EDD - CERF Pilot</b>	Total Award	Remaining	Match	Remaining Match	2024/2025 Yearly Impact
End Date: 10/2025	\$3,203,872.00	\$2,541,872.00	\$0.00	\$0.00	\$40,000

## 2024/2025 Grant Expense Narrative

### SAVE 2023/2024

The 2023/2024 SAVE grant project targets the removal of abandoned and derelict vessels. This program requires a 10% match, however staff time can be used as an in-kind donation. Typically per vessel, the Harbormaster will spend 15-20 hours at a rate of 32\$ per hour, this generally equates to half of the total match. If the in-kind match does not exceed the 10% match requirement, a cash match is taken from total reimbursement amount. In the 2024/2025 proposed budget the Harbor District should expect to pay \$2,000 from the general fund toward the cash match.

### State Lands Commission

The State Lands Commission grant is allocated into two separate projects, a vessel destruction project and grader park improvement project. The vessel destruction project has been completed and the grader park improvements projects are expected to be done by October 2025. The project is funded at 100% but staff time was not considered to be an applicable expense for this project. Work loads for this project vary as permits and contractors are aquired and work can be completed. On average the Harbormaster has spend 2 hours per week on this project throughout the life of the project. A one time payment was made to the Harbor District for that project and the funds have been placed in the LAIF account and slowly withdrawn as the District expended funds from this project.

### Economic Development Department- Community Emergency Relief Fund

The EDD-CERF project will construct the new ice making facility and host the Marine Based Entreprenural Training Program. This project was funded at 100% and funds have been allocated toward staff time and indirect cost incurred by the Harbor District. While this project has just begun, it should be reflected in the 2024/2025 budget that a portion of staff time and overhead are being reimbursed to the Harbor District. The Harbormaster has estimated that \$40,000 will be reimbursed to the District from these two categories. This reimbursement is shown in the "Other Revenues" category under Economic Developement Department.

Account/Reserve Information

**Current Cash Balances**

Chase Checking	\$187,915.79
Chase Money Market	\$156,125.24
LAIF	\$1,553,442.17
<b>Total</b>	<b>\$1,897,483.20</b>

**Total not pre-allocated to  
grant fundings**

	<b>\$1,765,563.99</b>
6 Month operating expense	\$270,000.00
Reserves	\$1,495,563.99

<b>Positions</b>	<b>Pay Rates</b>	<b>Salary</b>	<b>Hours Per Week</b>	<b>Total</b>
Harbormaster		70000.00	40	70,000.00
Marina Manager	30.00		40	62,400.00
Full Time Maintance	28.19		40	58,635.20
Part Time Maintance	19.50		30	30,420.00
Part Time Maintenance	19.50		30	30,420.00
<b>Totals</b>				<b>\$251,875</b>

# Noyo Harbor District

## Payroll summary by employee report

From Jul 01, 2023 to Mar 31, 2024 for all employees from all locations

Item	Total
<b>Hours - total</b>	<b>5003.81</b>
Hours - Regular Pay	3349.75
Hours - Overtime Pay	0
Hours - Bonus	0
Hours - Vacation Pay	113
Hours - Sick Pay	23
Hours - Holiday Pay	40
Hours - Salary	1478.06
<b>Gross pay - total</b>	<b>\$ 127,881.18</b>
Gross pay - Regular Pay	\$ 74,556.02
Gross pay - Overtime Pay	\$ 0.00
Gross pay - Bonus	\$ 0.00
Gross pay - Vacation Pay	\$ 3,364.10
Gross pay - Sick Pay	\$ 730.34
Gross pay - Holiday Pay	\$ 1,053.60
Gross pay - Salary	\$ 48,177.12
<b>Pretax deductions - total</b>	
<b>Adjusted gross</b>	<b>\$ 127,881.18</b>
<b>Other pay - total</b>	<b>\$ 0.00</b>
<b>Employee taxes &amp; deductions - total</b>	<b>-\$ 22,726.54</b>
<b>Employee taxes - total</b>	<b>-\$ 22,726.54</b>
Employee taxes - Federal Income Tax	-\$ 9,061.77
Employee taxes - Social Security	-\$ 7,928.62
Employee taxes - Medicare	-\$ 1,854.28
Employee taxes - CA Income Tax	-\$ 2,647.25
Employee taxes - CA State Disability Ins	-\$ 1,234.62
<b>Employee Aftertax deductions - total</b>	
<b>Net pay</b>	<b>\$ 105,154.64</b>
<b>Employer taxes &amp; contributions - total</b>	<b>\$ 10,379.33</b>
<b>Employer taxes - total</b>	<b>\$ 10,379.33</b>
Employer taxes - FUTA Employer	\$ 149.11
Employer taxes - Social Security Employer	\$ 7,928.62
Employer taxes - Medicare Employer	\$ 1,854.28
Employer taxes - CA ETT	\$ 24.85
Employer taxes - CA SUI Employer	\$ 422.47
<b>Company contributions - total</b>	
<b>Total payroll cost</b>	<b>\$ 138,260.51</b>





# NOYO HARBOR DISTRICT AGENDA ITEM SUMMARY

**AGENDA ITEM #: 5**  
**MEETING DATE: 5/9/2024**

## TITLE

Meeting Schedule

## ANALYSIS

The Harbormaster is requesting that the June meeting be moved to June 6<sup>th</sup>. The Harbormaster would like to go on maternity leave June 1<sup>st</sup> but would prefer to attend the June meeting. The two items up for discussion and possible action at the June meeting that the Harbormaster would like to participate in. The two topics are the award of any construction contracts for fish cleaning stations and the 2024/2025 budgets.

The Harbormaster is requesting that July and August meetings be as required. The Marina Manager and Harbormaster and Commissioners can communicate the need for meetings prior to posting and developing an agenda. The Harbormaster has tried to plan all projects and program to run smoothly with little interference while on maternity leave. However, topics may arise that require a meeting.

## FISCAL IMPACT

## ATTACHMENTS



**Page Left Blank**

## Staff Reports

### Port Infrastructure Development Program Grant

The Harbormaster will submit the PIDP grant on May 10<sup>th</sup> for Marina Redevelopment Phase 1. This project would plan, permit, design and redevelop 3 docks in the mooring basin. This project includes dredging around any new infrastructure, designs for a fuel dock and the retrofitting of the High Dock. Overall, this project is slated to cost \$11.1 million. The match for this project is \$783,000, hopefully the District's application to the State Coastal Conservancy will function as a match for this project.

### State Coastal Conservancy

The Harbormaster is working on an application for the planning and design of a new marina to be submitted to the State Coastal Conservancy. This project has a budget of \$750,000 and will hopefully serve as a match for the PIDP grant program. This application is due June 24<sup>th</sup> and will be submitted before the Harbormaster goes on maternity leave.

### Harbormaster Maternity Leave

The Harbormaster will start maternity leave on June 1<sup>st</sup> and return on September 2<sup>nd</sup>, 2024. The Marina Manager and Lead Maintenance will be available to fill in her position.